

# 18-Line SCSI Terminator

## FEATURES

- Complies with SCSI, SCSI-2, SCSI-3, SPI and FAST-20 Standards
- 2pF Channel Capacitance During Disconnect
- 50µA Supply Current in Disconnect Mode
- 110Ω Termination
- SCSI Hot Plugging Compliant, 10nA Typical
- +400mA Sinking Current for Active Negation
- -650mA Sourcing Current for Termination
- Trimmed Impedance to 5%
- Thermal Shutdown
- Current Limit

## DESCRIPTION

The UCC5618 provides 18 lines of active termination for a SCSI (Small Computers Systems Interface) parallel bus. The SCSI standard recommends and Fast-20 (Ultra) requires active termination at both ends of the cable.

Pin for pin compatible with the UC5601 and UC5608, the UCC5618 is ideal for high performance 5V SCSI systems,  $V_{TRMPWR}$  4.0-5.25V. During disconnect the supply current is only 50µA typical, which makes the IC attractive for lower powered systems.

The UCC5618 is designed with a low channel capacitance of 2pF, which eliminates effects on signal integrity from disconnected terminators at interim points on the bus.

The power amplifier output stage allows the UCC5618 to source full termination current and sink active negation current when all termination lines are actively negated.

The UCC5618, as with all Unitrode terminators, is completely hot pluggable and appears as high impedance at the terminating channels with  $V_{TRMPWR}=0V$  or open.

Internal circuit trimming is utilized, first to trim the 110Ω impedance, and then most importantly, to trim the output current as close to the max SCSI-3 spec as possible, which maximizes noise margin in fast SCSI operation.

This device is offered in low thermal resistance versions of the industry standard 28 pin wide body SOIC, TSSOP and PLCC.

## BLOCK DIAGRAM

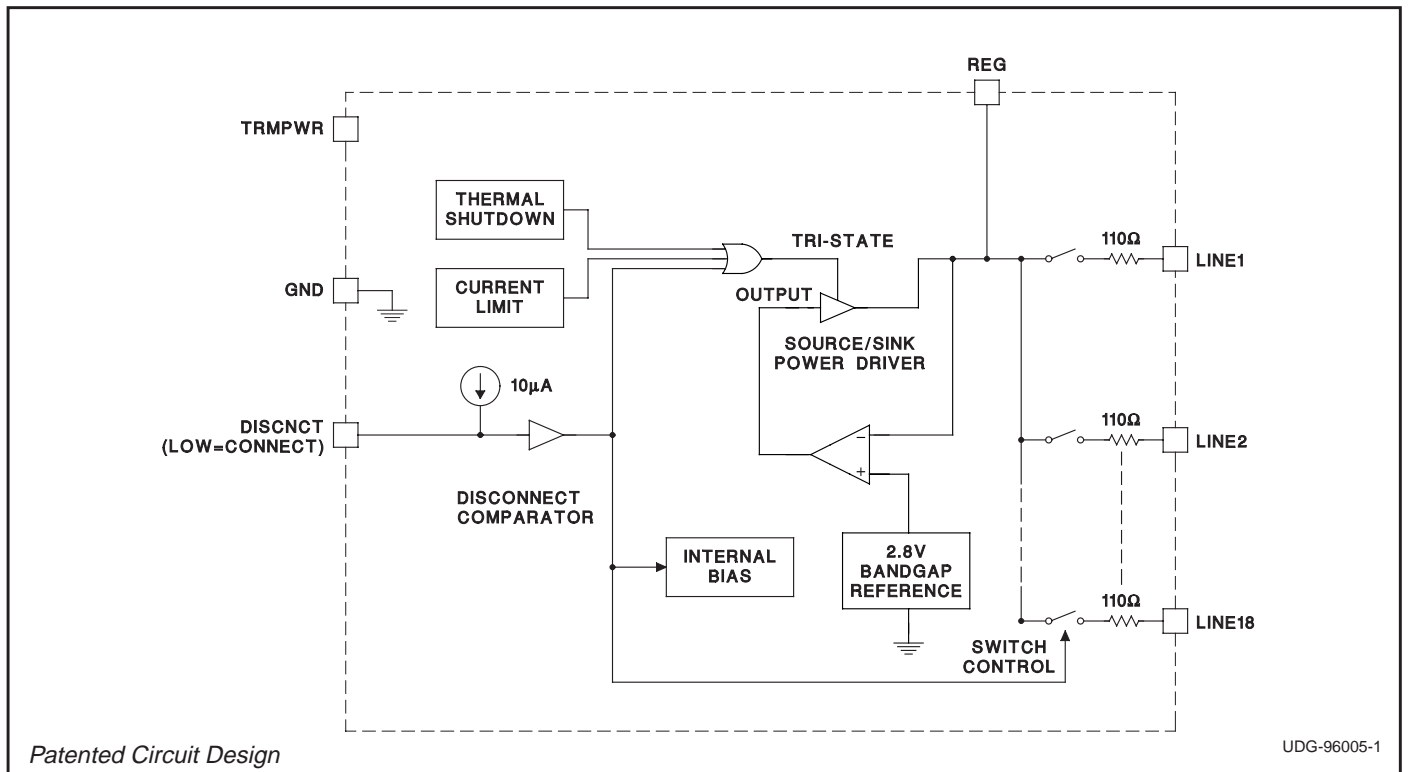

### ABSOLUTE MAXIMUM RATINGS

TEMPWR. ....	+7V
Signal Line Voltage .....	0V to +7V
Regulator Output Current .....	1A
Storage Temperature .....	-65°C to +150°C
Operating Junction Temperature .....	-55°C to +150°C
Lead Temperature (Soldering, 10 Seconds) .....	300°C

All currents are positive into, negative out of the specified terminal. Consult Packaging Section of Databook for thermal limitations and considerations of packages.

### CONNECTION DIAGRAMS

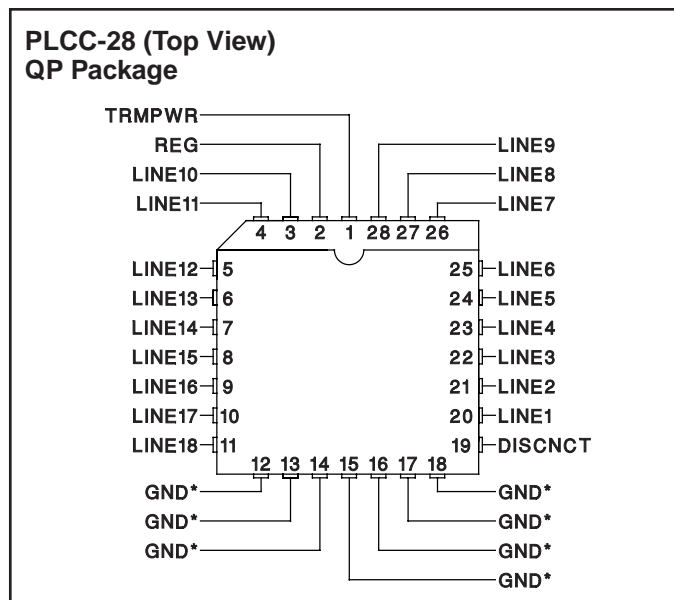

\* DWP package pins 12-18 serve as both heatsink and signal ground.

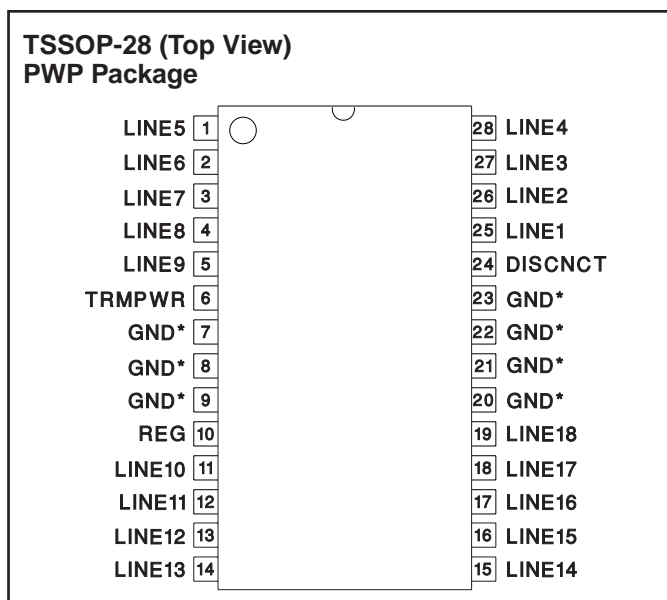

\* PWP package pin 23 serves as signal ground; pins 7, 8, 9, 20, 21, and 22 serve as heatsink ground.

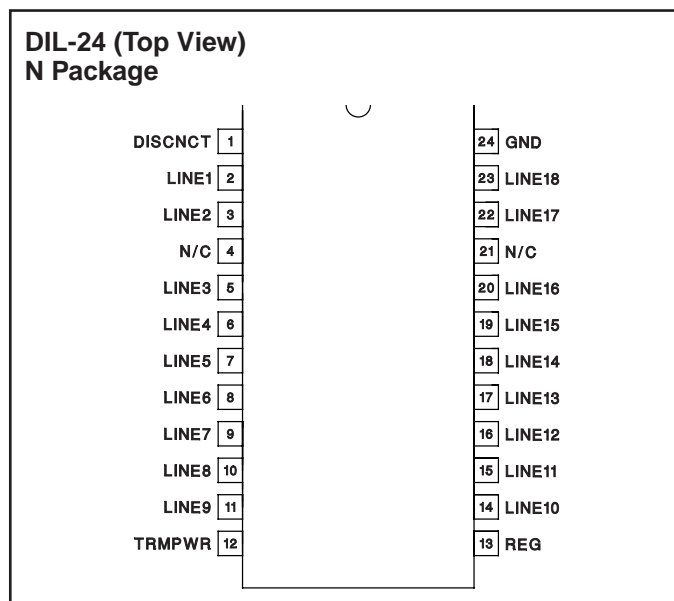

Note: Drawings are not to scale.

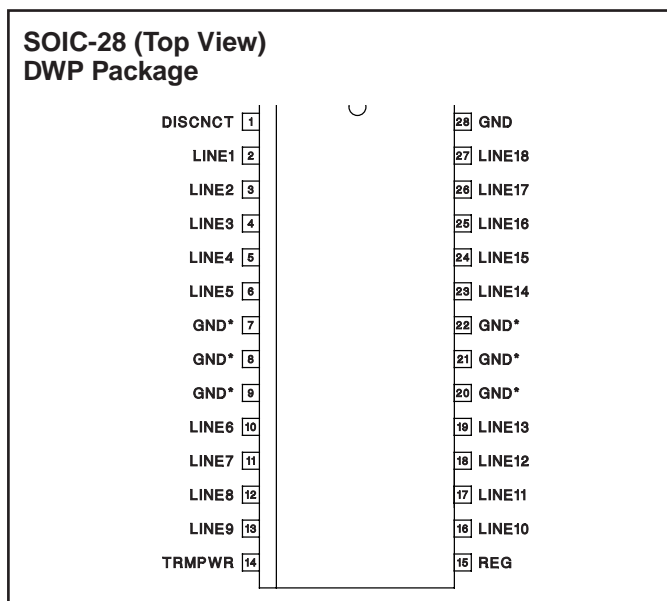

\* DWP package pin 28 serves as signal ground; pins 7, 8, 9, 20, 21, 22 serve as heatsink/ground.

**ELECTRICAL CHARACTERISTICS:** Unless otherwise stated these specifications apply for  $T_A = 0^\circ\text{C}$  to  $70^\circ\text{C}$ ,  $\text{TRMPWR} = 4.75\text{V}$ ,  $\text{DISCNCT} = 0\text{V}$ ,  $T_A = T_J$ .

PARAMETER	TEST CONDITIONS	MIN	TYP	MAX	UNITS
<b>Supply Current Section</b>					
TERMPWR Supply Current	All Termination Lines = Open		1	2	mA
	All Termination Lines = 0.2V		420	440	mA
Power Down Mode	DISCNCT = TRMPWR		50	100	$\mu\text{A}$
<b>Output Section (Termination Lines)</b>					
Termination Impedance	See Figure 1	104.5	110	115.5	$\Omega$
Output High Voltage	$V_{\text{TRMPWR}} = 4\text{V}$ (Note 1)	2.6	2.8	3	V
Max Output Current	$V_{\text{LINE}} = 0.2\text{V}$ , $T_J = 25^\circ\text{C}$	-22.1	-23.3	-24	mA
	$V_{\text{LINE}} = 0.2\text{V}$	-20.7	-23.3	-24	mA
	$V_{\text{LINE}} = 0.2\text{V}$ , $\text{TRMPWR} = 4\text{V}$ , $T_J = 25^\circ\text{C}$ (Note 1)	-21	-23.3	-24	mA
	$V_{\text{LINE}} = 0.2\text{V}$ , $\text{TRMPWR} = 4\text{V}$ (Note 1)	-20	-23	-24	mA
	$V_{\text{LINE}} = 0.5\text{V}$			-22.4	mA
Output Leakage	DISCNCT = 2.4V, TRMPWR = 0V to 5.25V, REG = 0.2V, $V_{\text{LINE}} = 5.25\text{V}$		10	400	nA
Output Capacitance	DISCNCT = 2.4V (Note 2)		2	3.5	pF
<b>Regulator Section</b>					
Regulator Output Voltage		2.6	2.8	3	V
Drop Out Voltage	All Termination Lines = 0.2V		0.4	0.8	V
Short Circuit Current	$V_{\text{REG}} = 0\text{V}$	-475	-650	-950	mA
Sinking Current Capability	$V_{\text{REG}} = 3.5\text{V}$	200	400	800	mA
Thermal Shutdown			170		$^\circ\text{C}$
Thermal Shutdown Hysteresis			10		$^\circ\text{C}$
<b>Disconnect Section</b>					
Disconnect Threshold		0.8	1.5	2	V
Input Current	DISCNCT = 0V		-10	-30	$\mu\text{A}$

Note 1: Measuring each termination line while other 17 are low (0.2V).

Note 2: Guaranteed by design. Not 100% tested in production.

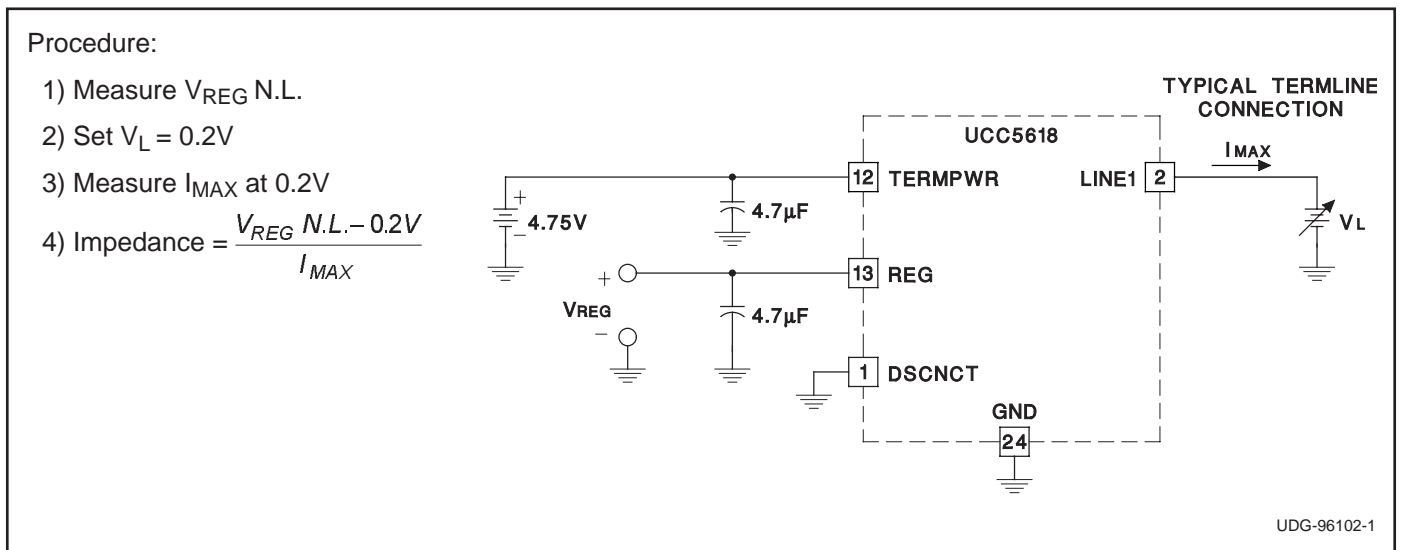

Figure 1. Termline Impedance Measurement Circuit

**PIN DESCRIPTIONS**

**DISCNCT:** Taking this pin high or leaving it open causes the 18 channels to become high impedance and the chip to go into low-power mode; a low state allows the channels to provide normal termination.

**GND:** Ground reference for the IC.

**LINE1–LINE18:** 110Ω termination channels.

**REG:** Output of the internal 2.8V regulator.

**TRMPWR:** Power for the IC.

**APPLICATION INFORMATION**

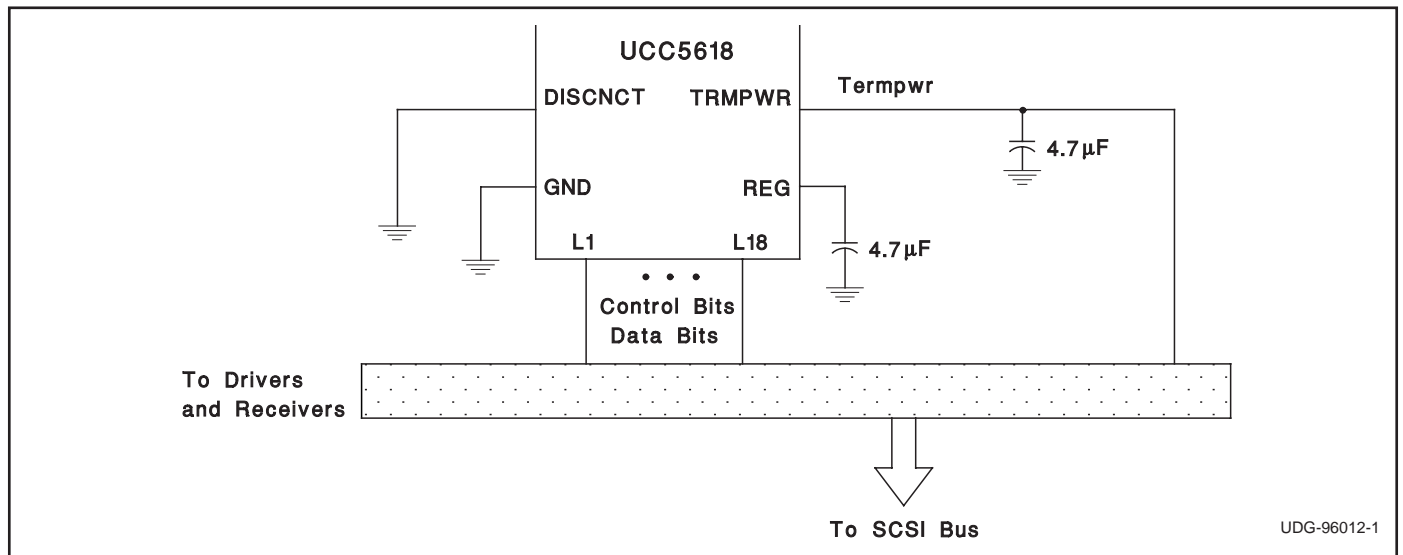

**PACKAGING INFORMATION**

Orderable Device	Status <sup>(1)</sup>	Package Type	Package Drawing	Pins	Package Qty	Eco Plan <sup>(2)</sup>	Lead/Ball Finish	MSL Peak Temp <sup>(3)</sup>
UCC5618DWP	ACTIVE	SOIC	DW	28	20	None	CU SNPB	Level-2-220C-1 YEAR
UCC5618DWPTR	ACTIVE	SOIC	DW	28	1000	None	CU SNPB	Level-2-220C-1 YEAR
UCC5618DWPTRG4	ACTIVE	SOIC	DW	28	1000	Green (RoHS & no Sb/Br)	CU NIPDAU	Level-2-260C-1 YEAR
UCC5618N	ACTIVE	PDIP	N	24	15	None	CU SNPB	Level-NA-NA-NA
UCC5618PWP	ACTIVE	TSSOP	PW	28	50	None	CU NIPDAU	Level-2-220C-1 YEAR
UCC5618PWPTR	ACTIVE	TSSOP	PW	28	2000	None	CU NIPDAU	Level-2-220C-1 YEAR
UCC5618QP	ACTIVE	PLCC	FN	28	37	None	CU SNPB	Level-2-220C-1 YEAR
UCC5618QPTR	ACTIVE	PLCC	FN	28	750	None	CU SNPB	Level-2-220C-1 YEAR

<sup>(1)</sup> The marketing status values are defined as follows:

**ACTIVE:** Product device recommended for new designs.

**LIFEBUY:** TI has announced that the device will be discontinued, and a lifetime-buy period is in effect.

**NRND:** Not recommended for new designs. Device is in production to support existing customers, but TI does not recommend using this part in a new design.

**PREVIEW:** Device has been announced but is not in production. Samples may or may not be available.

**OBSOLETE:** TI has discontinued the production of the device.

<sup>(2)</sup> Eco Plan - May not be currently available - please check <http://www.ti.com/productcontent> for the latest availability information and additional product content details.

**None:** Not yet available Lead (Pb-Free).

**Pb-Free (RoHS):** TI's terms "Lead-Free" or "Pb-Free" mean semiconductor products that are compatible with the current RoHS requirements for all 6 substances, including the requirement that lead not exceed 0.1% by weight in homogeneous materials. Where designed to be soldered at high temperatures, TI Pb-Free products are suitable for use in specified lead-free processes.

**Green (RoHS & no Sb/Br):** TI defines "Green" to mean "Pb-Free" and in addition, uses package materials that do not contain halogens, including bromine (Br) or antimony (Sb) above 0.1% of total product weight.

<sup>(3)</sup> MSL, Peak Temp. -- The Moisture Sensitivity Level rating according to the JEDEC industry standard classifications, and peak solder temperature.

**Important Information and Disclaimer:** The information provided on this page represents TI's knowledge and belief as of the date that it is provided. TI bases its knowledge and belief on information provided by third parties, and makes no representation or warranty as to the accuracy of such information. Efforts are underway to better integrate information from third parties. TI has taken and continues to take reasonable steps to provide representative and accurate information but may not have conducted destructive testing or chemical analysis on incoming materials and chemicals. TI and TI suppliers consider certain information to be proprietary, and thus CAS numbers and other limited information may not be available for release.

In no event shall TI's liability arising out of such information exceed the total purchase price of the TI part(s) at issue in this document sold by TI to Customer on an annual basis.

## IMPORTANT NOTICE

Texas Instruments Incorporated and its subsidiaries (TI) reserve the right to make corrections, modifications, enhancements, improvements, and other changes to its products and services at any time and to discontinue any product or service without notice. Customers should obtain the latest relevant information before placing orders and should verify that such information is current and complete. All products are sold subject to TI's terms and conditions of sale supplied at the time of order acknowledgment.

TI warrants performance of its hardware products to the specifications applicable at the time of sale in accordance with TI's standard warranty. Testing and other quality control techniques are used to the extent TI deems necessary to support this warranty. Except where mandated by government requirements, testing of all parameters of each product is not necessarily performed.

TI assumes no liability for applications assistance or customer product design. Customers are responsible for their products and applications using TI components. To minimize the risks associated with customer products and applications, customers should provide adequate design and operating safeguards.

TI does not warrant or represent that any license, either express or implied, is granted under any TI patent right, copyright, mask work right, or other TI intellectual property right relating to any combination, machine, or process in which TI products or services are used. Information published by TI regarding third-party products or services does not constitute a license from TI to use such products or services or a warranty or endorsement thereof. Use of such information may require a license from a third party under the patents or other intellectual property of the third party, or a license from TI under the patents or other intellectual property of TI.

Reproduction of information in TI data books or data sheets is permissible only if reproduction is without alteration and is accompanied by all associated warranties, conditions, limitations, and notices. Reproduction of this information with alteration is an unfair and deceptive business practice. TI is not responsible or liable for such altered documentation.

Resale of TI products or services with statements different from or beyond the parameters stated by TI for that product or service voids all express and any implied warranties for the associated TI product or service and is an unfair and deceptive business practice. TI is not responsible or liable for any such statements.

Following are URLs where you can obtain information on other Texas Instruments products and application solutions:

<b>Products</b>		<b>Applications</b>	
Amplifiers	<a href="http://amplifier.ti.com">amplifier.ti.com</a>	Audio	<a href="http://www.ti.com/audio">www.ti.com/audio</a>
Data Converters	<a href="http://dataconverter.ti.com">dataconverter.ti.com</a>	Automotive	<a href="http://www.ti.com/automotive">www.ti.com/automotive</a>
DSP	<a href="http://dsp.ti.com">dsp.ti.com</a>	Broadband	<a href="http://www.ti.com/broadband">www.ti.com/broadband</a>
Interface	<a href="http://interface.ti.com">interface.ti.com</a>	Digital Control	<a href="http://www.ti.com/digitalcontrol">www.ti.com/digitalcontrol</a>
Logic	<a href="http://logic.ti.com">logic.ti.com</a>	Military	<a href="http://www.ti.com/military">www.ti.com/military</a>
Power Mgmt	<a href="http://power.ti.com">power.ti.com</a>	Optical Networking	<a href="http://www.ti.com/opticalnetwork">www.ti.com/opticalnetwork</a>
Microcontrollers	<a href="http://microcontroller.ti.com">microcontroller.ti.com</a>	Security	<a href="http://www.ti.com/security">www.ti.com/security</a>
		Telephony	<a href="http://www.ti.com/telephony">www.ti.com/telephony</a>
		Video & Imaging	<a href="http://www.ti.com/video">www.ti.com/video</a>
		Wireless	<a href="http://www.ti.com/wireless">www.ti.com/wireless</a>

Mailing Address: Texas Instruments  
Post Office Box 655303 Dallas, Texas 75265

This datasheet has been download from:

[www.datasheetcatalog.com](http://www.datasheetcatalog.com)

Datasheets for electronics components.