

Octal Line Driver

FEATURES

- Eight Single Ended Line Drivers in One Package
- Meets EIA Standards EIA232E/V.28, EIA423A and CCITT V.10/X.26
- Single External Resistor Controls Slew Rate
- Wide Supply Voltage Range
- Tri-State Outputs
- Output Short-Circuit Protection

DESCRIPTION

The UC5170C is a single-ended octal line driver designed to meet both standard modem control applications (EIA232E/V.28), and long line drive applications (EIA423A/V.10/X.26). The slew rate for all eight drivers is controlled by a single external resistor. The slew rate and output levels in Low Mode are independent of the power variations.

Mode selection is easily accomplished by taking the select pins (Ms+ and Ms-) to ground for low output mode (EIA232E/V.28 and EIA423A/V.10) or to their respective supplies for high mode (EIA232E/V.28). High mode should only be used to drive adapters that take power from the control lines, or applications using high threshold receivers.

ABSOLUTE MAXIMUM RATINGS (Note 1)

| | |
|--|-----------------|
| V+ (Pin 20) | 15V |
| V- (Pin 11) | -15V |
| PLCC Power Dissipation, TA = 25°C (Note 2) | 1000 mW |
| DIP Power Dissipation, TA = 25°C (Note 2) | 1250 mW |
| Input Voltage | -1.5V to +7V |
| Output Voltage | -12V to +12V |
| Slew Rate Resistor | 2k to 10kΩ |
| Storage Temperature | -65°C to +150°C |

Note 1: All voltages are with respect to ground, pin 18.

Note 2: Consult Packaging Section of Databook for thermal limitations and considerations of packages.

FUNCTIONAL TABLE

| INPUTS | | OUTPUTS | |
|------------------------|------|---------------------------------|------------------------|
| $\overline{\text{EN}}$ | DATA | HIGH EIA-232E ⁽²⁾ | LOW EIA423A+EIA232E |
| 0 | 0 | (V+)-3V | 5V to 6V |
| 0 | 1 | (V-)-3V | -5V to -6V |
| 1 | X | High Z | High Z |

Note 2: Minimum output swings.

CONNECTION DIAGRAMS

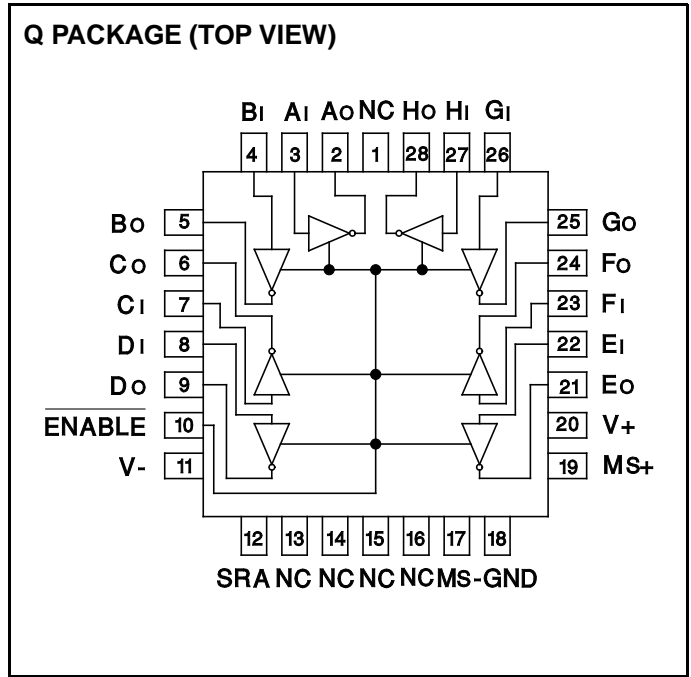
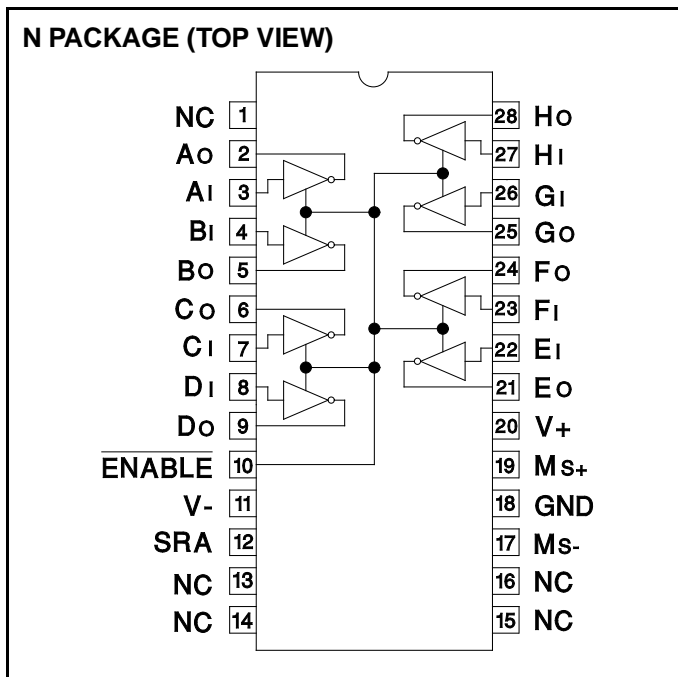

DC ELECTRICAL CHARACTERISTICS: Unless otherwise stated these specifications hold for $|V_+| = |V_-| = 10V$, $0 < T_A < +70^\circ C$, $M_{S+} = M_{S-} = 0V$, $R_{SRA} = +10k$, $T_A = T_J$.

| PARAMETERS | SYMBOL | TEST CONDITIONS | MIN | TYP | MAX | UNITS |
|--|------------------|--|------|------|------|-------|
| POWER SUPPLY REQUIREMENTS | | | | | | |
| V+ Range | | | 9 | | 15 | V |
| V- Range | | | -9 | | -15 | V |
| V+ Supply Current | I+ | $R_L = \text{Infinite}$ $\overline{E_n} = 0V$ | | 25 | 42 | mA |
| V- Supply Current | I- | $R_L = \text{Infinite}$ $\overline{E_n} = 0V$ | | -23 | -42 | mA |
| INPUTS | | | | | | |
| High Level Input Voltage | V _{IH} | | 2.0 | | | V |
| Low Level Input Voltage | V _{IL} | | | | 0.8 | V |
| Input Clamp Voltage | V _{IK} | I _I = -15 mA | | -1.1 | -1.8 | V |
| High Level Input Current | I _{IH} | V _{IH} = 2.4V | | 0.25 | 40 | μA |
| Low Level Input Current | I _{IL} | V _{IL} = 0.4V | -200 | -8.0 | | μA |
| OUTPUTS | | | | | | |
| High Level (Low Mode) Output Voltage (EIA423A/V.10, EIA232E/V.28) | V _{OH} | V _{IN} = 0.8V $R_L = \text{Inf.}$ | 5.0 | 5.3 | 6.0 | V |
| | | $\overline{E_n} = 0.8V$ $R_L = 3k$ | 5.0 | 5.3 | 6.0 | V |
| | | $R_L = 450$ | 4.5 | 5.2 | 6.0 | V |
| Low Level (Low Mode) Output Voltage (EIA423A/V.10, EIA232E/V.28) | V _{OL} | V _{IN} = 2.0V $R_L = \text{Inf.}$ | -5.0 | -5.3 | -6.0 | V |
| | | $\overline{E_n} = 0.8V$ $R_L = 3k$ | -5.0 | -5.3 | -6.0 | V |
| | | $R_L = 450$ | -4.5 | -5.2 | -6.0 | V |
| Output Balance (EIA423A/V.10) | V _{BAL} | $R_L = 450$ $V_{OH} - V_{OL} = V_{BAL}$ | | 0.2 | 0.4 | V |
| High Level (High Mode) Output Voltage (EIA232E/V.28) | V _{OH} | V _{IN} = 0.8V $R_L = \text{Inf.}$, $M_{S+} = V_+$, $M_{S-} = V_-$ | 7.0 | 7.6 | 10 | V |
| | | $\overline{E_n} = 0.8V$ $R_L = 3k$, $M_{S+} = V_+$, $M_{S-} = V_-$ | 7.0 | 7.6 | 10 | V |
| Low Level (High Mode) Output Voltage (EIA232E, V.28) | V _{OL} | V _{IN} = 2.0V $R_L = \text{Inf.}$, $M_{S+} = V_+$, $M_{S-} = V_-$ | -7.0 | -7.7 | -10 | V |
| | | $\overline{E_n} = 0.8V$ $R_L = 3k$, $M_{S+} = V_+$, $M_{S-} = V_-$ | -7.0 | -7.7 | -10 | V |
| Off-State Output Current | I _{OZ} | $\overline{E_n} = 2.0V$, $V_o = \pm 6V$, $V_+ = 15V$, $V_- = -15V$ | -100 | | 100 | μA |
| Short-Circuit Current | I _{OS} | V _{IN} = 0V, $\overline{E_n} = 0V$ | -25 | -50 | | mA |
| | | V _{IN} = 5V, $\overline{E_n} = 0V$ | 25 | 40 | | mA |

AC ELECTRICAL CHARACTERISTICS: at $|V_+| = |V_-| = 10V$, $0 < T_A < +70^\circ C$, $M_{S+} = M_{S-} = 0V$, $T_A = T_J$.

| PARAMETERS | SYMBOL | TEST CONDITIONS | MIN | TYP | MAX | UNITS |
|---|-----------------|----------------------------|------|-----|------|-------|
| Output Slew Rate | t _R | $R_{SRA} = 2k$ | 6.65 | 9.5 | 12.3 | V/μs |
| | t _F | $R_L = 450$, $C_L = 50pF$ | 6.65 | 10 | 12.3 | V/μs |
| Output Slew Rate | t _R | $R_{SRA} = 10k$ | 1.33 | 1.9 | 2.45 | V/μs |
| | t _F | $R_L = 450$, $C_L = 50pF$ | 1.33 | 2.2 | 2.45 | V/μs |
| Propagation Output to High Impedance | t _{HZ} | $R_{SRA} = 10k$ | | 0.3 | 1.0 | μs |
| | t _{LZ} | $R_L = 450$, $C_L = 50pF$ | | 0.5 | 2.0 | μs |
| Propagation High Impedance to Output | t _{ZH} | $R_{SRA} = 10k$ | | 6.0 | 17 | μs |
| | t _{ZL} | $R_L = 450$, $C_L = 50pF$ | | 7.0 | 17 | μs |

AC PARAMETER TEST CIRCUIT AND WAVEFORMS

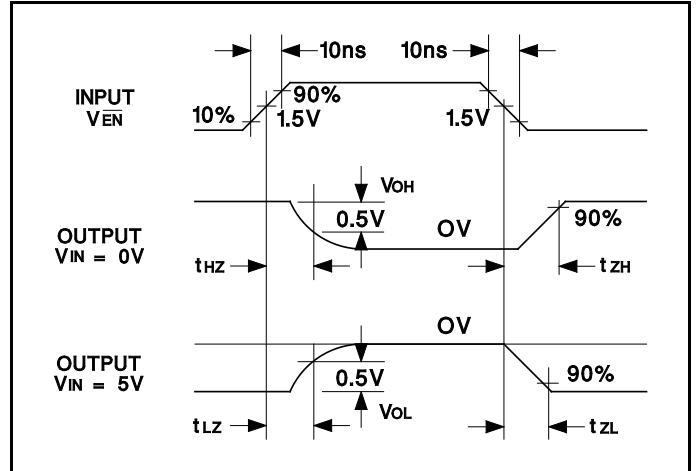
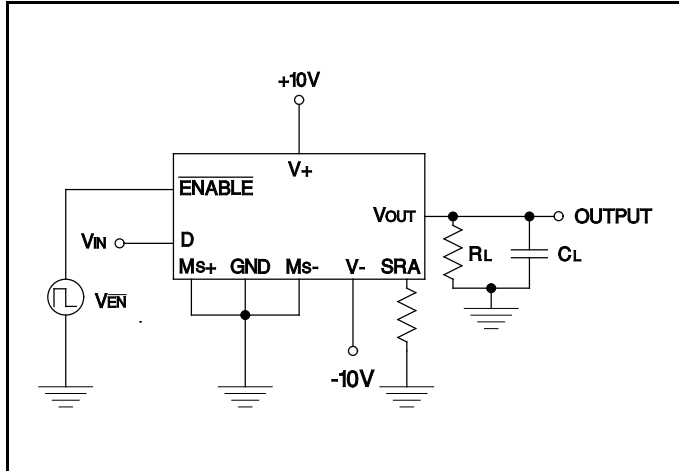

AC CHARACTERISTICS

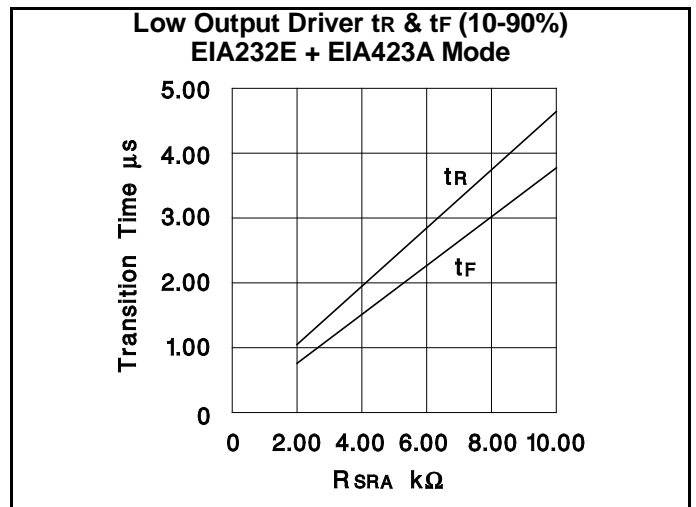
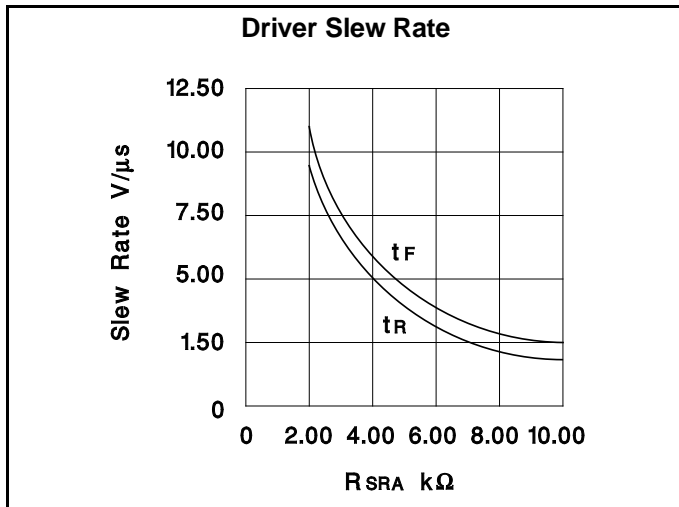

APPLICATION INFORMATION

Slew Rate Programming

Slew rate for the UC5170C is set up by a single external resistor connected between the SRA pin and ground. Slew rate adjustments can be approximated by using the following formula:

$$V/\mu s = \frac{20}{R_{SRA}} (R_{SRA} \text{ in } k\Omega)$$

The slew rate resistor can vary between 2k and 10k which allows slew rates between 10 to 2.2V/μs, respectively. The relationship between slew rate and RSRA is shown in the typical characteristics.

Waveshaping of the output lets the user control the level of interference (near-end crosstalk) that may be coupled to adjacent circuits in an interconnection. The recommended output characteristics for cable length and data rates can be found in EIA standard EIA423A +V.10. Approximations of these standards are given by the following equations:

Max. Data Rate = 300/t (For data rates 1k to 100k bit/s)

Max. Cable Length (feet) = 100 x t (Max. length 4000 feet)

where t is the transition time from 10% to 90% of the output swing in microseconds. For data rates below 1k bit/s t may be up to 300 microseconds.

Output Voltage Programming

The UC5170C has two programmable output modes, either a low voltage mode which meets EIA423A, EIA232E/V.28/V.10 specifications, or the high output mode which meets the EIA232E, V.28 specifications.

The high output mode provides greater output swings, minimum of 3V below and supply rails for driving higher, attenuated lines. This mode is selected by connecting the mode select pins to their respected supplies, Ms+ to V+ and Ms- to V-.

The low output mode provides a controlled output swing and is accomplished by connecting both mode select pins to ground.

APPLICATIONS

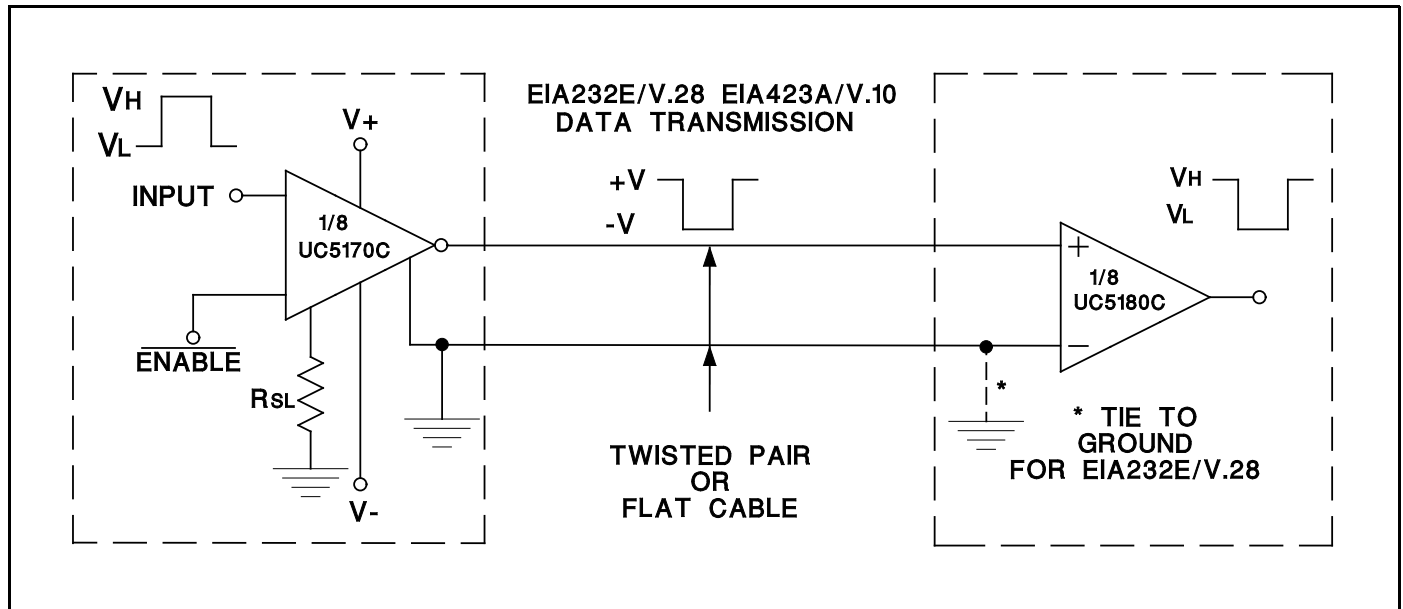

SPECIFIC LAYOUT NOTES

The UC5170C layout must have bulk bypassing close to the device. Peak slew current is greater than 500mA when all eight drivers slew at once in the same direction. Some applications mount the UC5170C on a bulkhead or isolated plane for RFI/FCC/VDE reasons. If bulk bypassing is not used, the -10V supply may go above -8.5 volts, causing the slew rate control circuit to become unstable.

The UC5170C can have output oscillation at 100kHz if the +10V supply is applied before the -10V supply. This has been a problem in some terminal designs where the +10V was developed from the flyback, which can result in a 500ms difference in the application of the supplies at power up.

GENERAL LAYOUT NOTES

The drivers and receivers should be mounted close to the system common ground point, with the ground reference tied to the common point to reduce RFI/EMI.

Filter connectors or transzorb should be used to reduce the RFI/EMI, protecting the system from static (ESD), and electrical overstress (EOS). A filter connector or capacitor will reduce the ESD pulse by 90% typically. A cable dragged across a carpet and connected to a system can easily be charged to over 25,00 volts. This is a metal to metal contact when the cable is connected to the system (no resistance), currents exceed 80 amps with less than a nanosecond rise time. A transzorb provides two functions, the device capacitance inherently acts as a filter capacitor, and the device clamps the ESD and EOS pulses which would pass through the capacitor and destroy the devices. The recommended transzorb for the UC5170C is P6KEIOCA.

*Transzorb is a trademark of General Semiconductor Industries.

PACKAGING INFORMATION

| Orderable Device | Status ⁽¹⁾ | Package Type | Package Drawing | Pins | Package Qty | Eco Plan ⁽²⁾ | Lead/Ball Finish | MSL Peak Temp ⁽³⁾ |
|------------------|-----------------------|--------------|-----------------|------|-------------|-------------------------|------------------|------------------------------|
| UC5170CJ | OBSOLETE | CDIP | J | 28 | | None | Call TI | Call TI |
| UC5170CN | OBSOLETE | | UTR | | | None | Call TI | Call TI |
| UC5170CQ | ACTIVE | PLCC | FN | 28 | 37 | None | CU SNPB | Level-2-220C-1 YEAR |
| UC5170CQTR | ACTIVE | PLCC | FN | 28 | 750 | None | CU SNPB | Level-2-220C-1 YEAR |

⁽¹⁾ The marketing status values are defined as follows:

ACTIVE: Product device recommended for new designs.

LIFEBUY: TI has announced that the device will be discontinued, and a lifetime-buy period is in effect.

NRND: Not recommended for new designs. Device is in production to support existing customers, but TI does not recommend using this part in a new design.

PREVIEW: Device has been announced but is not in production. Samples may or may not be available.

OBSOLETE: TI has discontinued the production of the device.

⁽²⁾ Eco Plan - May not be currently available - please check <http://www.ti.com/productcontent> for the latest availability information and additional product content details.

None: Not yet available Lead (Pb-Free).

Pb-Free (RoHS): TI's terms "Lead-Free" or "Pb-Free" mean semiconductor products that are compatible with the current RoHS requirements for all 6 substances, including the requirement that lead not exceed 0.1% by weight in homogeneous materials. Where designed to be soldered at high temperatures, TI Pb-Free products are suitable for use in specified lead-free processes.

Green (RoHS & no Sb/Br): TI defines "Green" to mean "Pb-Free" and in addition, uses package materials that do not contain halogens, including bromine (Br) or antimony (Sb) above 0.1% of total product weight.

⁽³⁾ MSL, Peak Temp. -- The Moisture Sensitivity Level rating according to the JEDEC industry standard classifications, and peak solder temperature.

Important Information and Disclaimer: The information provided on this page represents TI's knowledge and belief as of the date that it is provided. TI bases its knowledge and belief on information provided by third parties, and makes no representation or warranty as to the accuracy of such information. Efforts are underway to better integrate information from third parties. TI has taken and continues to take reasonable steps to provide representative and accurate information but may not have conducted destructive testing or chemical analysis on incoming materials and chemicals. TI and TI suppliers consider certain information to be proprietary, and thus CAS numbers and other limited information may not be available for release.

In no event shall TI's liability arising out of such information exceed the total purchase price of the TI part(s) at issue in this document sold by TI to Customer on an annual basis.

J (R-GDIP-T**)

CERAMIC DUAL-IN-LINE PACKAGE

24 PINS SHOWN

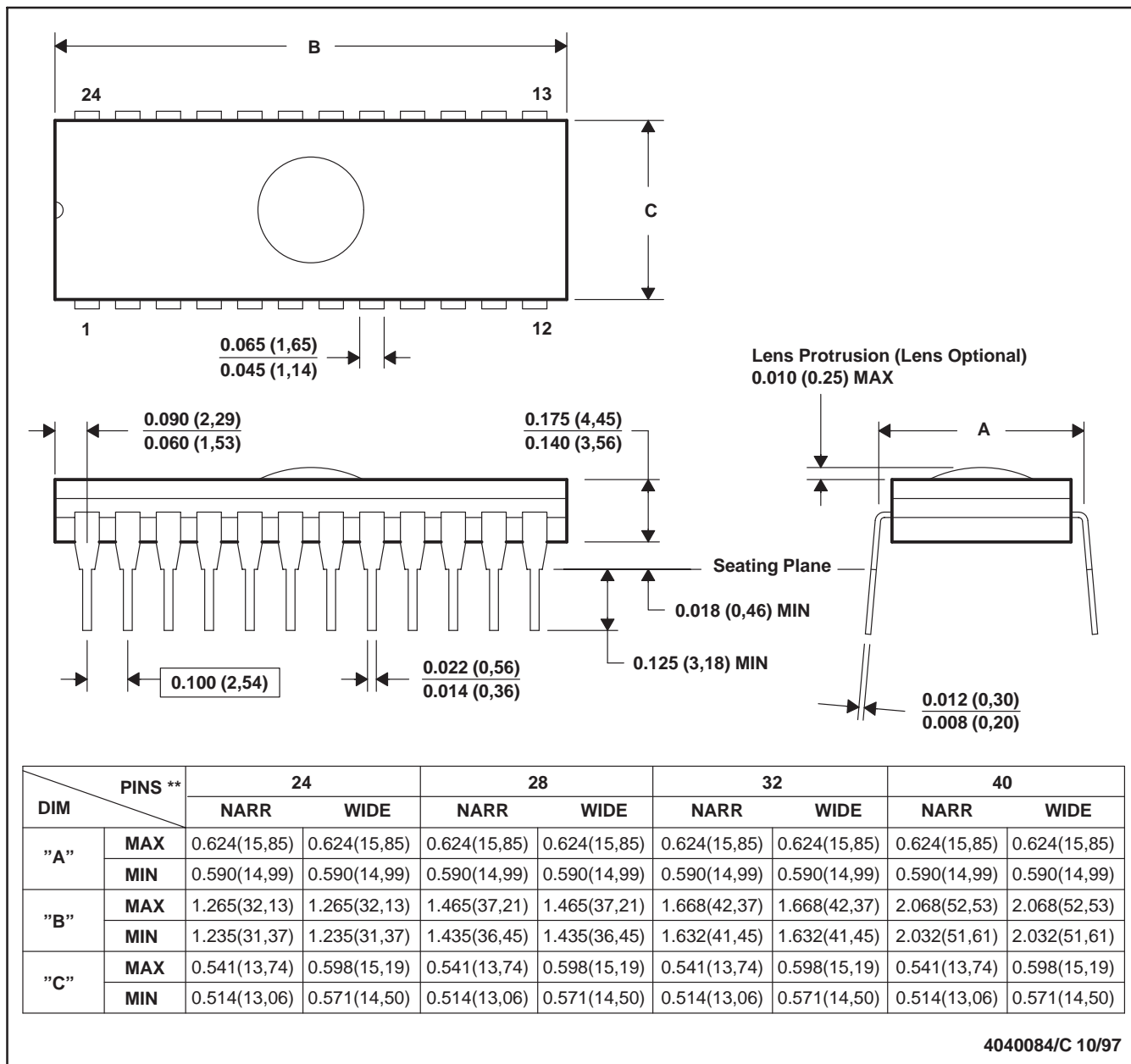

- NOTES: A. All linear dimensions are in inches (millimeters).
 B. This drawing is subject to change without notice.
 C. Window (lens) added to this group of packages (24-, 28-, 32-, 40-pin).
 D. This package can be hermetically sealed with a ceramic lid using glass frit.
 E. Index point is provided on cap for terminal identification.

FN (S-PQCC-J**)

PLASTIC J-LEADED CHIP CARRIER

20 PIN SHOWN

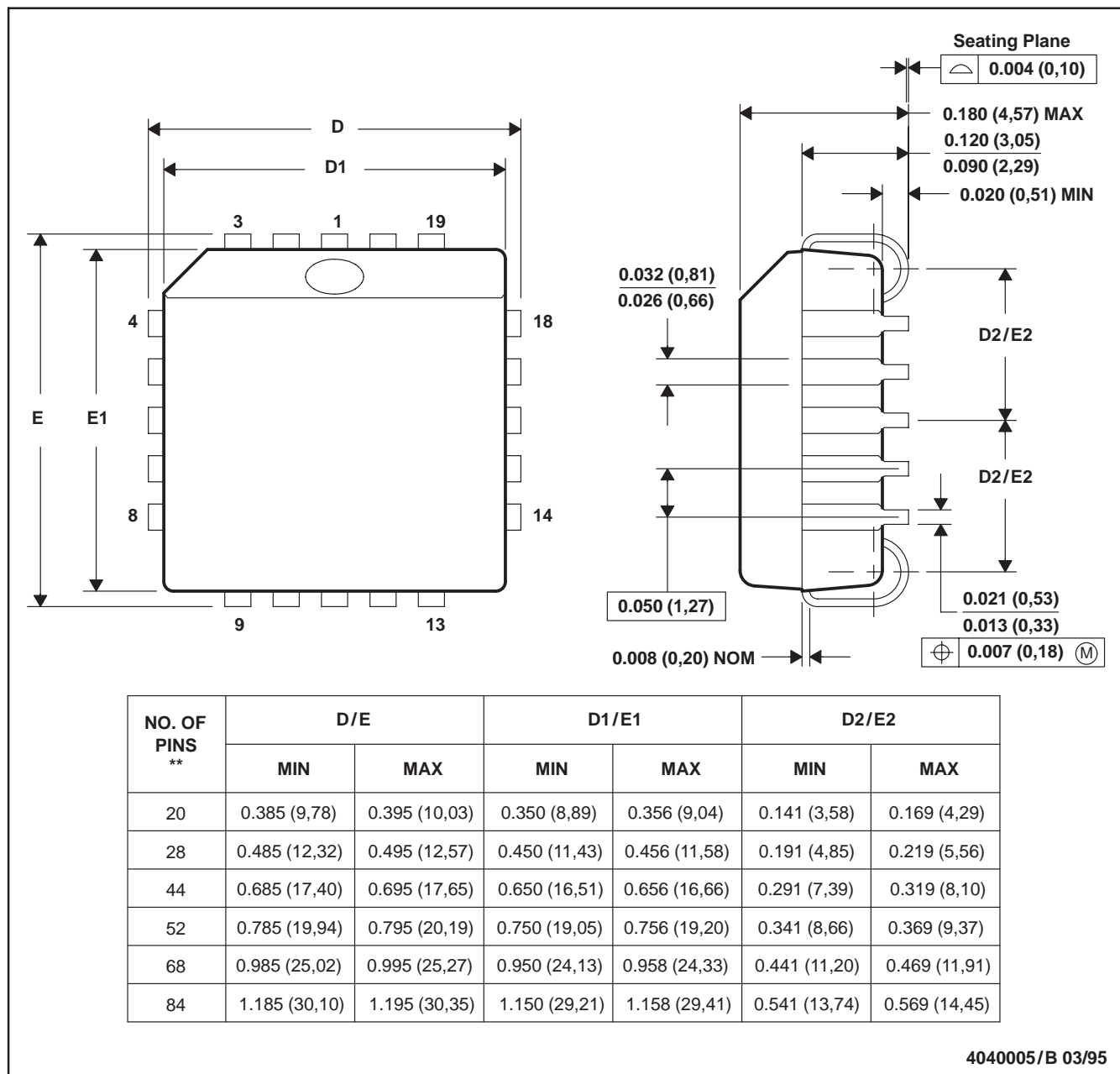

- NOTES: A. All linear dimensions are in inches (millimeters).
 B. This drawing is subject to change without notice.
 C. Falls within JEDEC MS-018

IMPORTANT NOTICE

Texas Instruments Incorporated and its subsidiaries (TI) reserve the right to make corrections, modifications, enhancements, improvements, and other changes to its products and services at any time and to discontinue any product or service without notice. Customers should obtain the latest relevant information before placing orders and should verify that such information is current and complete. All products are sold subject to TI's terms and conditions of sale supplied at the time of order acknowledgment.

TI warrants performance of its hardware products to the specifications applicable at the time of sale in accordance with TI's standard warranty. Testing and other quality control techniques are used to the extent TI deems necessary to support this warranty. Except where mandated by government requirements, testing of all parameters of each product is not necessarily performed.

TI assumes no liability for applications assistance or customer product design. Customers are responsible for their products and applications using TI components. To minimize the risks associated with customer products and applications, customers should provide adequate design and operating safeguards.

TI does not warrant or represent that any license, either express or implied, is granted under any TI patent right, copyright, mask work right, or other TI intellectual property right relating to any combination, machine, or process in which TI products or services are used. Information published by TI regarding third-party products or services does not constitute a license from TI to use such products or services or a warranty or endorsement thereof. Use of such information may require a license from a third party under the patents or other intellectual property of the third party, or a license from TI under the patents or other intellectual property of TI.

Reproduction of information in TI data books or data sheets is permissible only if reproduction is without alteration and is accompanied by all associated warranties, conditions, limitations, and notices. Reproduction of this information with alteration is an unfair and deceptive business practice. TI is not responsible or liable for such altered documentation.

Resale of TI products or services with statements different from or beyond the parameters stated by TI for that product or service voids all express and any implied warranties for the associated TI product or service and is an unfair and deceptive business practice. TI is not responsible or liable for any such statements.

Following are URLs where you can obtain information on other Texas Instruments products and application solutions:

| Products | | Applications | |
|------------------|--|---------------------|--|
| Amplifiers | amplifier.ti.com | Audio | www.ti.com/audio |
| Data Converters | dataconverter.ti.com | Automotive | www.ti.com/automotive |
| DSP | dsp.ti.com | Broadband | www.ti.com/broadband |
| Interface | interface.ti.com | Digital Control | www.ti.com/digitalcontrol |
| Logic | logic.ti.com | Military | www.ti.com/military |
| Power Mgmt | power.ti.com | Optical Networking | www.ti.com/opticalnetwork |
| Microcontrollers | microcontroller.ti.com | Security | www.ti.com/security |
| | | Telephony | www.ti.com/telephony |
| | | Video & Imaging | www.ti.com/video |
| | | Wireless | www.ti.com/wireless |

Mailing Address: Texas Instruments
Post Office Box 655303 Dallas, Texas 75265

This datasheet has been download from:

www.datasheetcatalog.com

Datasheets for electronics components.