

### Typical Applications

- 3V CDMA/AMPS Cellular Handsets
- 3V JCDMA/TACS Cellular Handsets
- 3V TDMA/AMPS Cellular Handsets
- Spread-Spectrum Systems
- CDPD Portable Data Cards
- Portable Battery-Powered Equipment

### Product Description

The RF2152 is a high-power, high-efficiency linear amplifier IC targeting 3V handheld systems. The device is manufactured on an advanced Gallium Arsenide Hetero-junction Bipolar Transistor (HBT) process, and has been designed for use as the final RF amplifier in dual-mode 3V CDMA/AMPS handheld digital cellular equipment, spread-spectrum systems, and other applications in the 800MHz to 950MHz band. The device is self-contained with 50Ω input and the output can be easily matched to obtain optimum power, efficiency, and linearity characteristics. The package is a PSSOP-16 with backside ground.

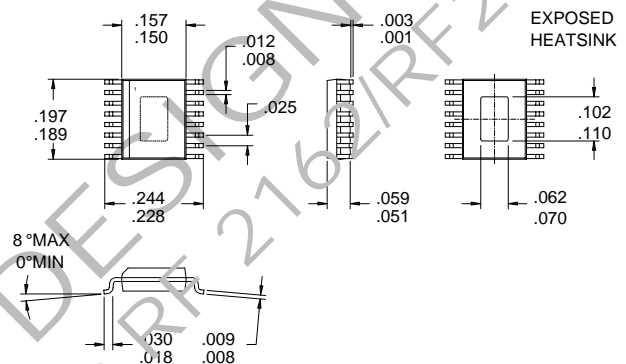

Refer to "Handling of PSOP and PSSOP Products" on page 16-15 for special handling information.

### Optimum Technology Matching® Applied

- Si BJT       GaAs HBT       GaAs MESFET  
 Si Bi-CMOS       SiGe HBT       Si CMOS

Package Style: PSSOP-16

### Features

- Single 3V Supply
- 28dBm Linear Output Power
- 30dB Linear Gain
- 35% Linear Efficiency
- On-board Power Down Mode
- 800MHz to 960MHz Operation

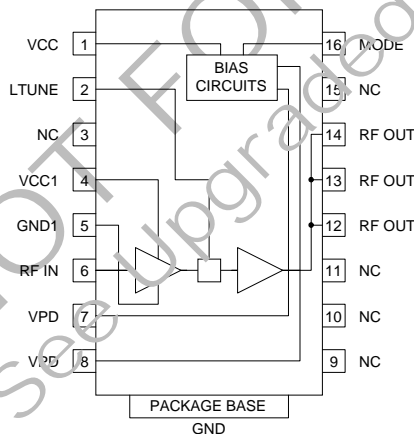

Functional Block Diagram

### Ordering Information

RF2152	Dual-Mode CDMA/AMPS or TDMA/AMPS 3V Power Amplifier
RF2152 PCBA-N	Fully Assembled Evaluation Board 824-849MHz
RF2152 PCBA-J	Fully Assembled Evaluation Board 877-924MHz

RF Micro Devices, Inc.  
7625 Thorndike Road  
Greensboro, NC 27409, USA

Tel (336) 664 1233  
Fax (336) 664 0454  
<http://www.rfmd.com>

# RF2152

## Absolute Maximum Ratings

Parameter	Rating	Unit
Supply Voltage (RF off)	+8.0	V <sub>DC</sub>
Supply Voltage (P <sub>OUT</sub> ≤31dBm)	+5.2	V <sub>DC</sub>
DC Supply Current	1.0	A
Mode Voltage (V <sub>MODE</sub> )	+3.0	V <sub>DC</sub>
Control Voltage (V <sub>PD</sub> )	+3.0	V <sub>DC</sub>
Input RF Power	+12	dBm
Operating Ambient Temperature	-40 to +85	°C
Storage Temperature	-40 to +150	°C
Moisture Sensitivity	JEDEC LEVEL 5	

Refer to "Handling of PSOP and PSSOP Products" on page 16-15 for special handling information.



**Caution!** ESD sensitive device.

RF Micro Devices believes the furnished information is correct and accurate at the time of this printing. However, RF Micro Devices reserves the right to make changes to its products without notice. RF Micro Devices does not assume responsibility for the use of the described product(s).

Parameter	Specification			Unit	Condition
	Min.	Typ.	Max.		
<b>Overall</b>					T=25°C, V <sub>CC</sub> =3.4V, V <sub>PD</sub> =2.8V, Freq=824MHz to 849MHz, unless otherwise specified
Usable Frequency Range	800		960	MHz	
Typical Frequency Range		824-849 877-925		MHz MHz	
Linear Gain	28	30	33	dB	P <sub>out</sub> =28dBm
Second Harmonic (including second harmonic trap)	-32	-38	-42	dBc	
Max CW Output Power	31	31.5	32	dBm	Tuned for CDMA
Total Efficiency (AMPS mode)	40	45	55	%	
Maximum Linear Output Power (CDMA Modulation)	28	28.5	29	dBm	Tuned for CDMA
Total Linear Efficiency	30	35	38	%	
Adjacent Channel Power Rejection	-44	-46	-50	dBc	ACPR @885kHz
Adjacent Channel Power Rejection	-56	-58	-62	dBc	ACPR @1980kHz
Input VSWR		< 2:1			
Output Load VSWR			10:1		No oscillations
Noise Figure	5.9	6.0	6.1	dB	V <sub>CC</sub> =3.4V
Noise Power P <sub>OUT</sub> =15dBm		86.5		dBm	V <sub>CC</sub> =3.4V; 30KHz BW; RX Band NP measured from TX center band to RX center band
P <sub>OUT</sub> =28dBm		89.3		dBm	
P <sub>OUT</sub> =31dBm		92.3		dBm	
<b>Power Supply</b>					
Power Supply Voltage	3.0	3.4	5.2	V	
Idle current		90		mA	MODE = low Pin 16=Ground AMPS/Low Power CDMA Modes
Idle current		200		mA	MODE = high Pin 16=2.8V High Power CDMA Mode (P <sub>out</sub> >20dBm)
V <sub>PD</sub> current		10		mA	Pins 7,8, V <sub>pd</sub> =2.8V (Pin 7 typ. not connected, I=5mA for Pin 8)
Turn On/Off time			<100	ns	
Total Current (Power down)			10	µA	V <sub>PD</sub> = low
V <sub>PD</sub> "Low" Voltage		0	0.2	V	
V <sub>PD</sub> "High" Voltage	2.7	2.8	2.9	V	
MODE "High" Voltage	2.1	2.8	2.9	V	
MODE "Low" Voltage		0	0.5	V	

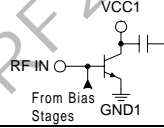
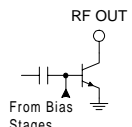
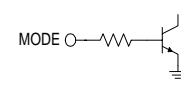
Pin	Function	Description	Interface Schematic
1	<b>VCC</b>	Power supply for input bias circuitry. A 100 pF high frequency bypass capacitor is recommended.	
2	<b>LTUNE</b>	Interstage tuning. This pin will connect to a shunt inductor used for interstage tuning. For 824MHz to 849MHz a 1.5nH discrete inductor is used; for 877MHz to 925MHz a shorted transmission line presenting 0.7 nH of inductance or discrete inductor may be used. This inductor should be placed as close to the pin as possible.	
3	<b>NC</b>	No connection. Grounding pin is recommended.	
4	<b>VCC1</b>	Power supply for stage 1. $V_{CC}$ should be fed through a 25nH or greater inductor with a decoupling capacitor on the $V_{CC}$ side.	See pin 6.
5	<b>GND1</b>	Ground for stage 1. Keep traces physically short and connect immediately to ground plane for best performance. This ground should be isolated from the backside ground contact.	See pin 6.
6	<b>RF IN</b>	RF input. An external DC blocking capacitor is required if this port is connected to a DC path to ground or a DC voltage.	
7	<b>VPD</b>	Power Down control. When this pin is "low", all circuits are shut off. When this pin is 2.8 volts, all circuits are operating normally. $V_{PD}$ requires a regulated 2.8 V for the amplifier to operate properly over all specified temperature and voltage ranges. A dropping resistor from a higher regulated voltage may be used to provide the required 2.8 V. A 100 pF high frequency bypass capacitor is recommended.	
8	<b>VPD</b>	Connect to pin 7.	
9	<b>NC</b>	No connection. Grounding pin is recommended.	
10	<b>NC</b>	No connection. Grounding pin is recommended.	
11	<b>NC</b>	No connection. Grounding pin is recommended.	
12	<b>RF OUT</b>	RF output and power supply for the output stage. The bias for the output stage is provided through this pin and pin 13. An external matching network is required to provide the optimum load impedance; see the application schematics for details. The first shunt cap of the matching circuit should be placed as close to the pin as possible.	
13	<b>RF OUT</b>	Same as pin 12.	See pin 12.
14	<b>RF OUT</b>	Harmonic trap. This pin connects to the RF output but is used for providing a low impedance to the second harmonic of the operating frequency. An inductor or transmission line resonating with a shunt capacitor at $2f_0$ is connected to this pin.	See pin 12.
15	<b>NC</b>	No connection. Grounding pin is recommended.	
16	<b>MODE</b>	The mode pin allows higher efficiency operation in AMPS and low power CDMA modes. MODE should be set "low" for highest efficiency in AMPS/TACS and in low power (<+15 dBm) CDMA operation. MODE should be set "high" for best linearity in high power CDMA operation.	
<b>Pkg Base</b>	<b>GND</b>	Ground connection. The backside of the package should be soldered to a top side ground pad which is connected to the ground plane with multiple vias. The pad should have a short thermal path to the ground plane.	

## Application Schematic 824MHz to 849MHz

2

POWER AMPLIFIERS

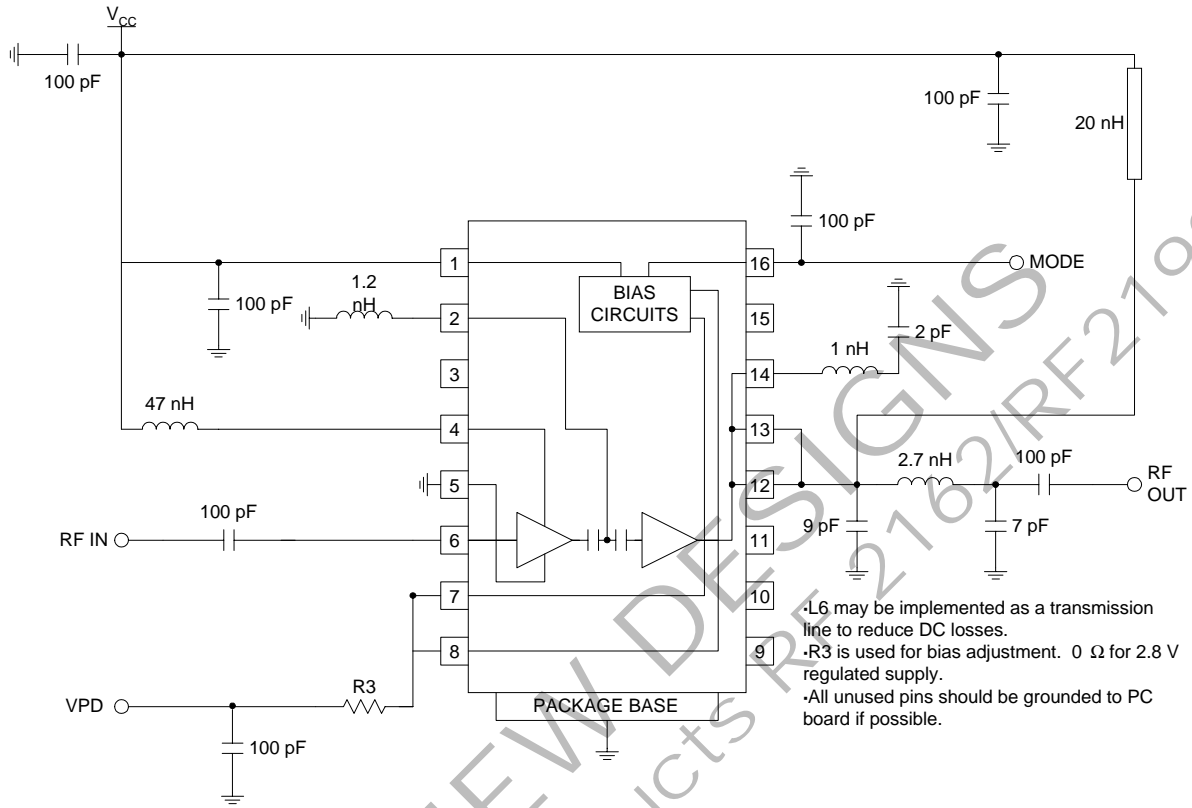

- L6 may be implemented as a transmission line to reduce DC losses.
- R3 is used for bias adjustment. 0  $\Omega$  for 2.8 V regulated supply.
- All unused pins should be grounded to PC board if possible.

NOT FOR NEW DESIGNS  
See Upgraded Products RF2162/RF2192

## Application Schematic 877MHz to 924MHz

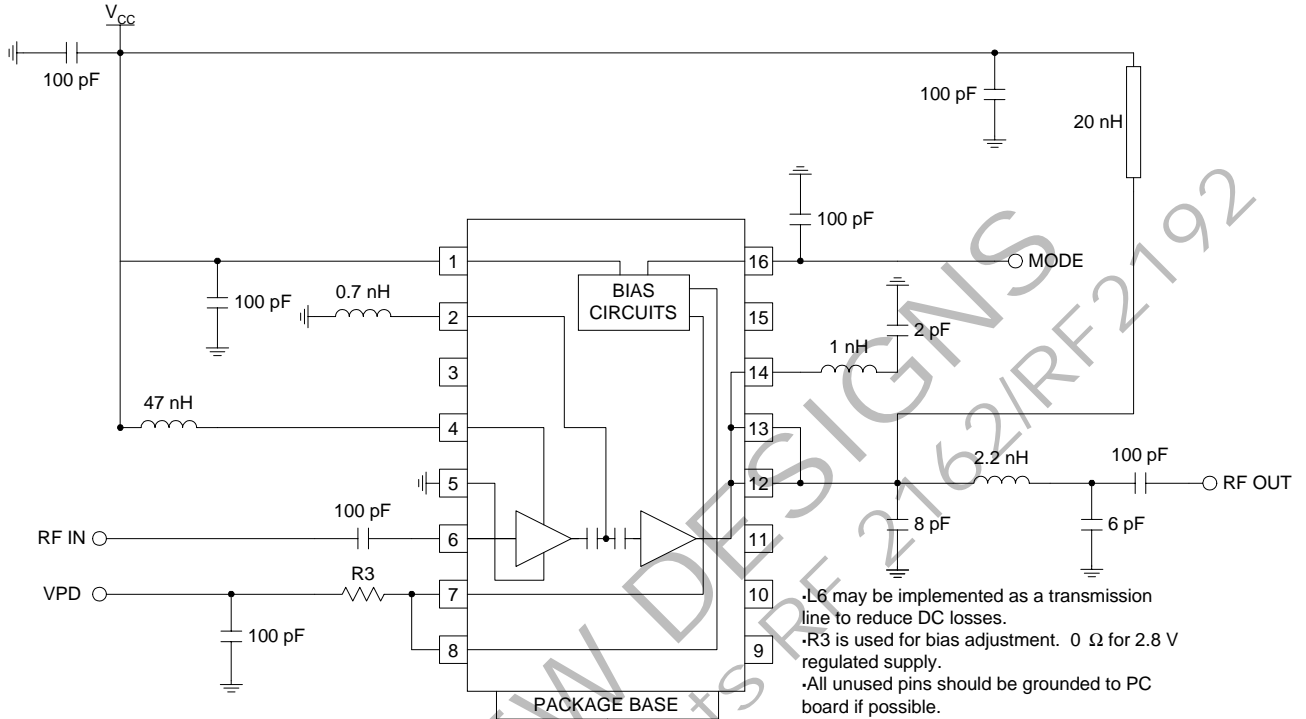

## Evaluation Board Schematic 824MHz to 849MHz

(Download [Bill of Materials](http://www.rfmd.com) from [www.rfmd.com](http://www.rfmd.com).)

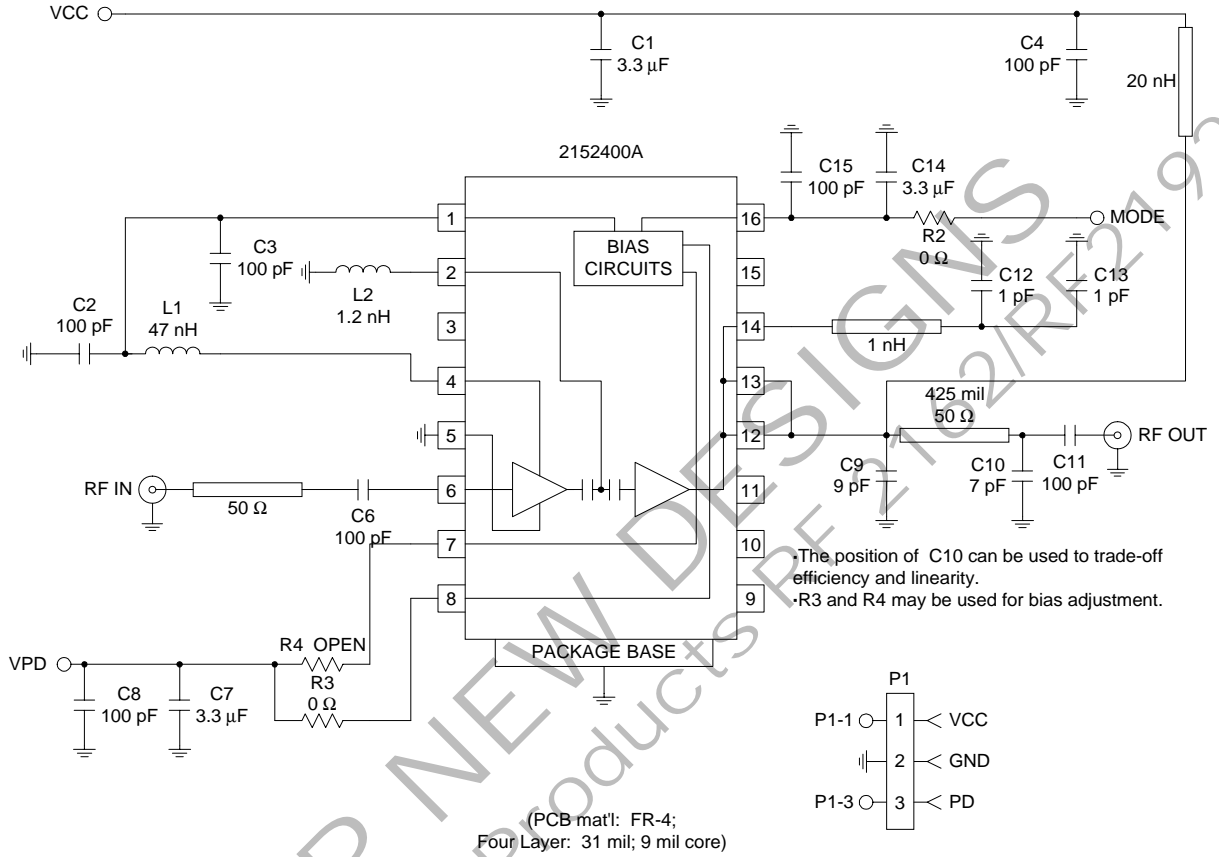

## Evaluation Board Schematic 877MHz to 924MHz

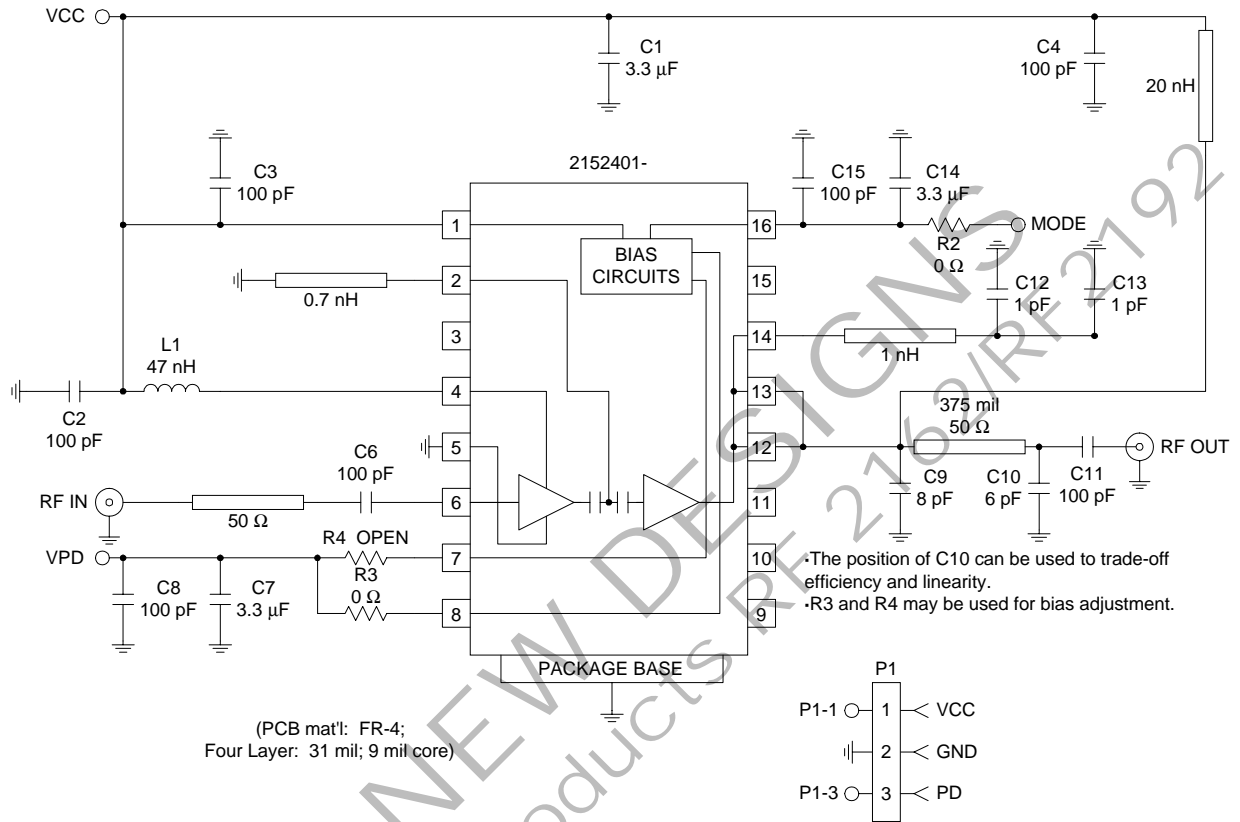

# RF2152

## Evaluation Board Layout 824MHz to 849MHz 1" x 1"

Board Thickness 0.034", Board Material FR-4, Multi-Layer

2

POWER AMPLIFIERS

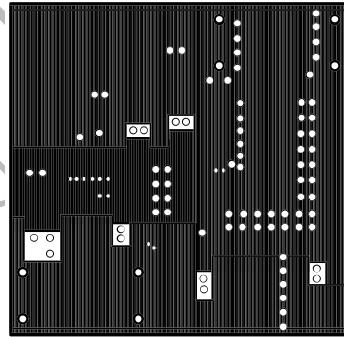
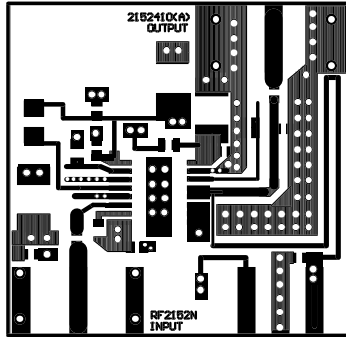
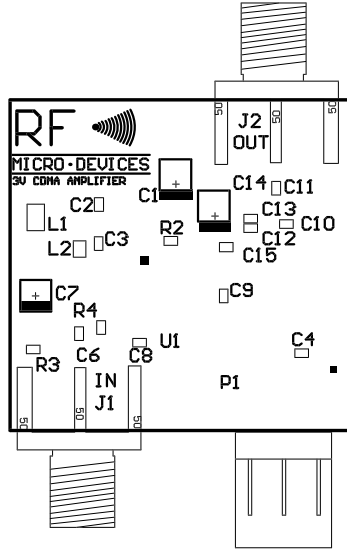

NOT FOR SALE  
See Upgraded Product  
DESIGNS  
2162/RF2192



Evaluation Board Layout 877MHz to 924MHz  
1" x 1"

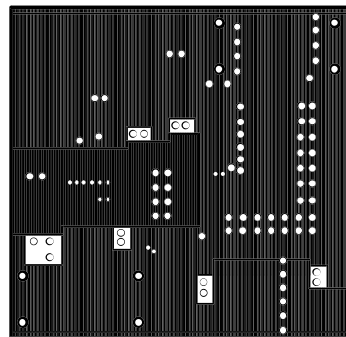
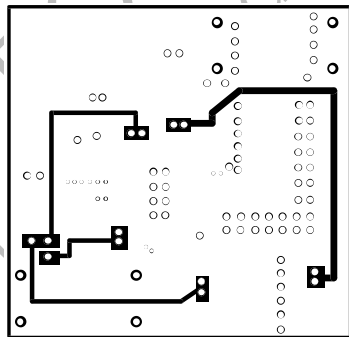
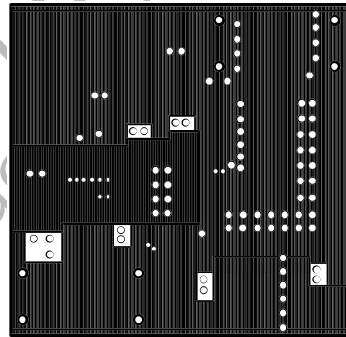
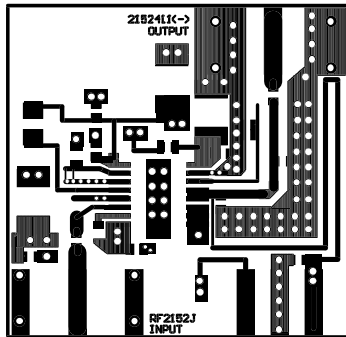
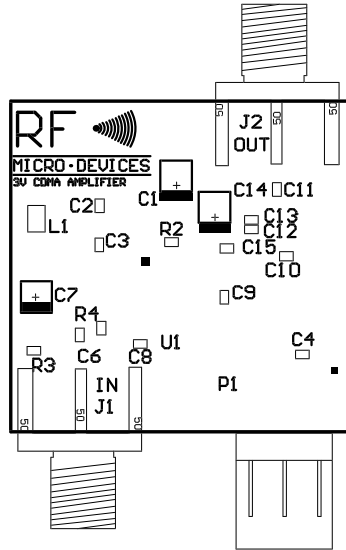

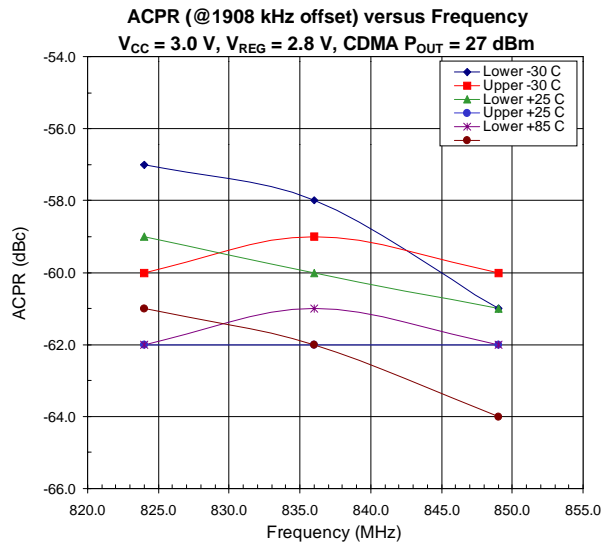
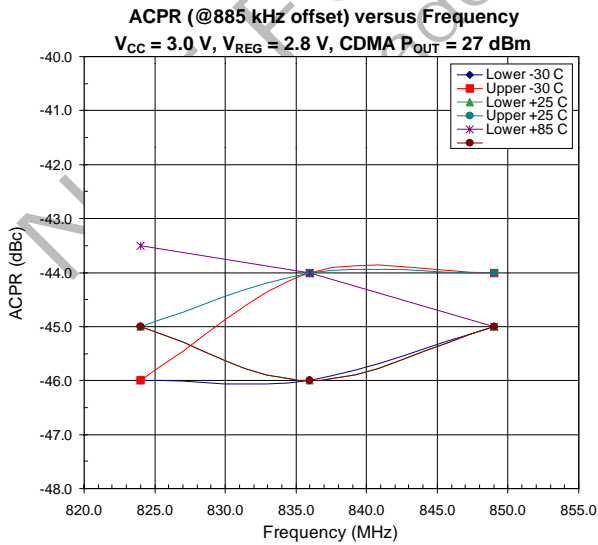
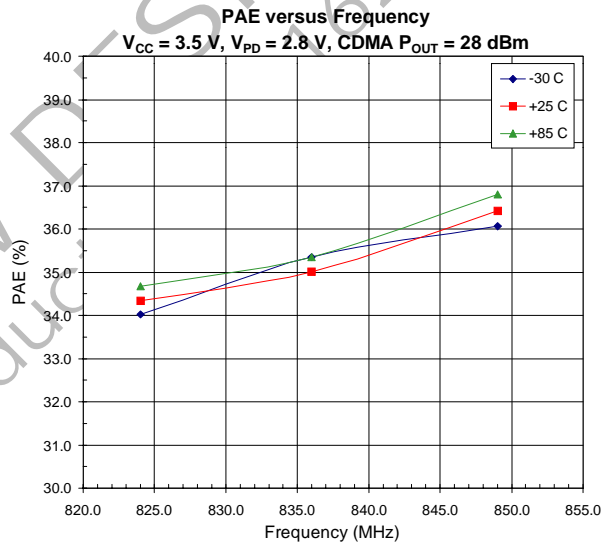
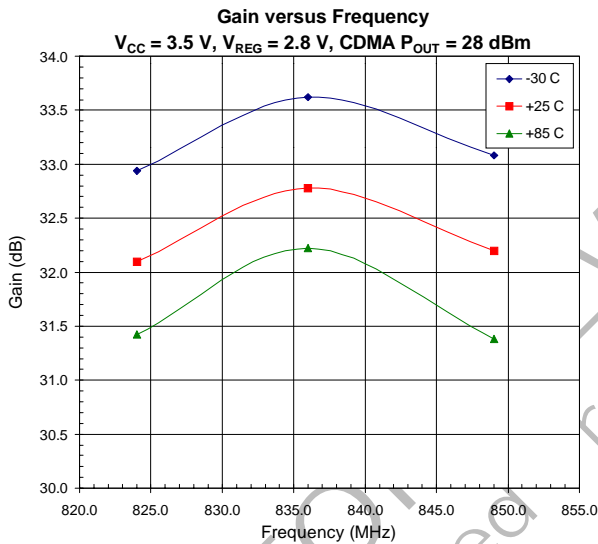
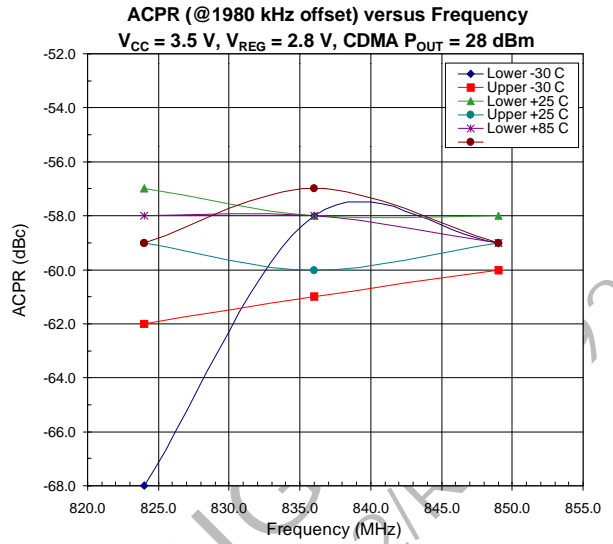
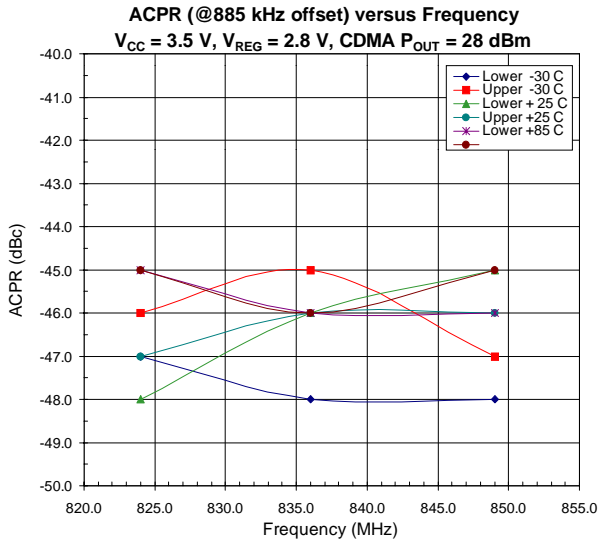

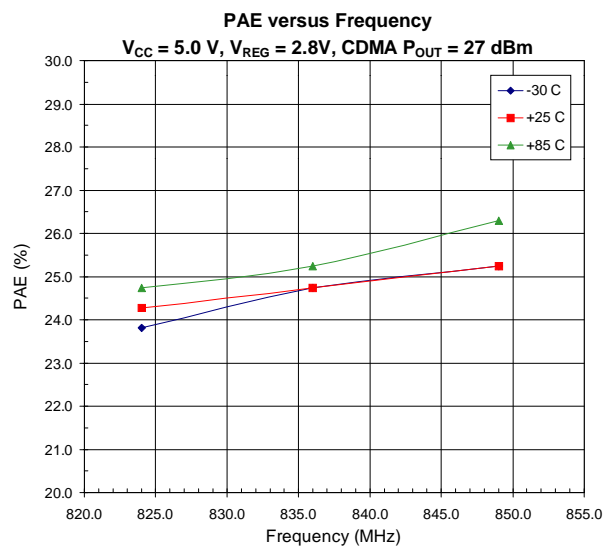
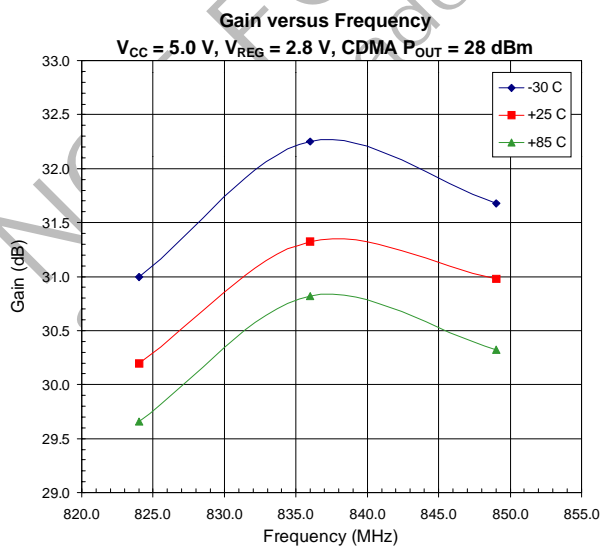
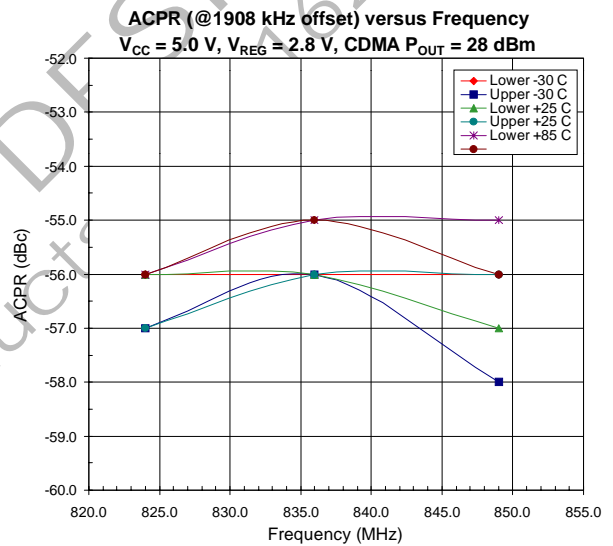
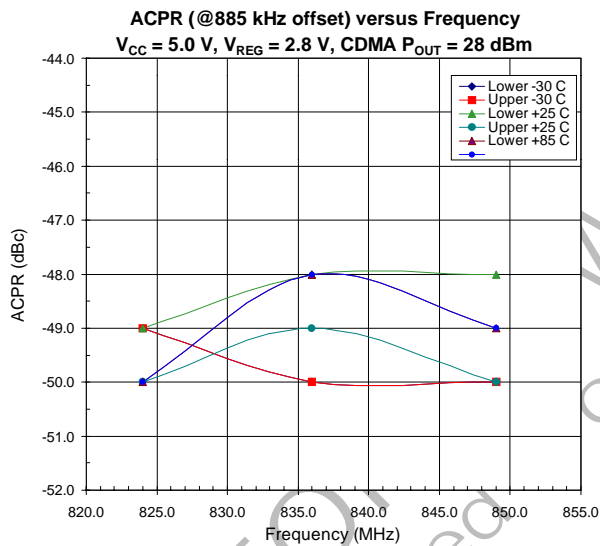
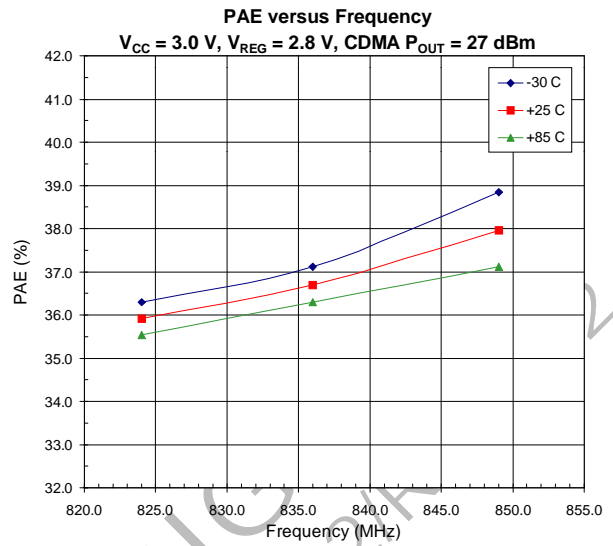
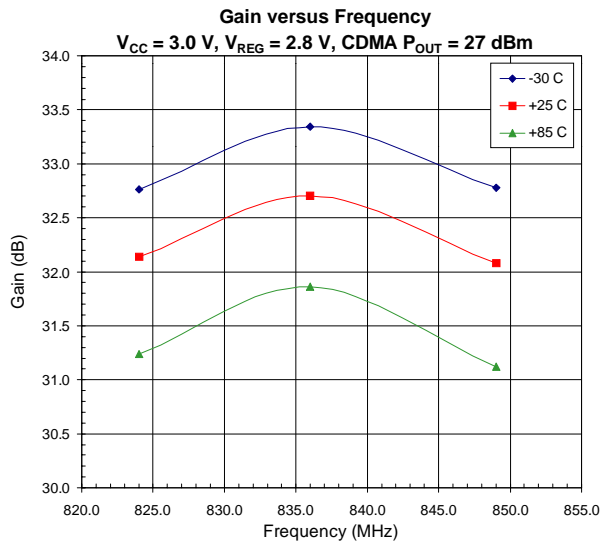

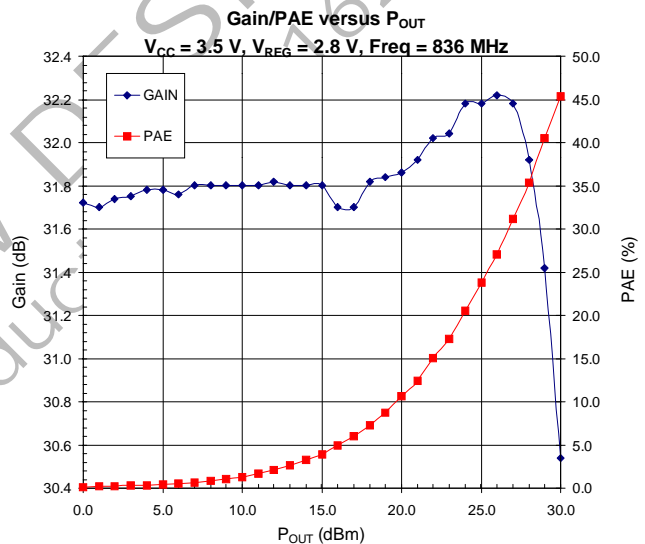
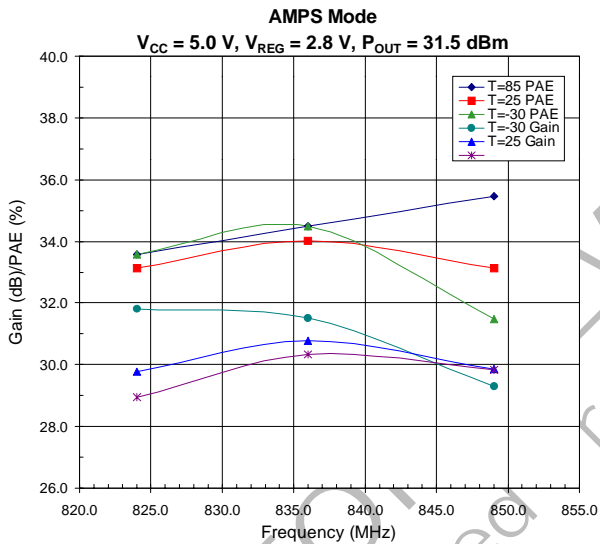
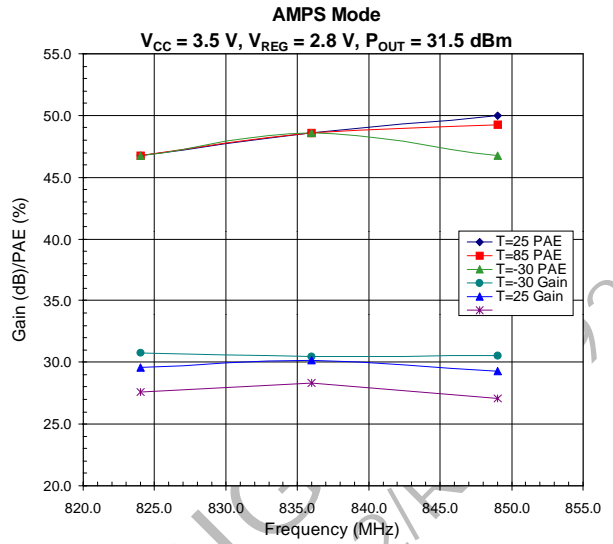
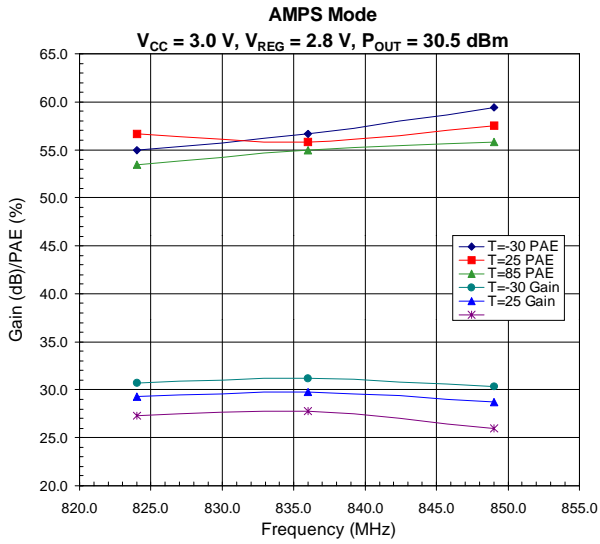

This datasheet has been download from:

[www.datasheetcatalog.com](http://www.datasheetcatalog.com)

Datasheets for electronics components.