

**FEATURES**

- incorporates GR504, 3 stage amplifier chip
- designed to drive class D integrated receivers
- adjustable symmetrical peak clipper for MPO control
- two low noise inverting preamplifiers
- mid-supply referenced output stage
- anti-aliasing filter network

**STANDARD PACKAGING**

- Hybrid Typical Dimensions:  
0.244 in x 0.102 in x 0.115 in  
(6.20 mm x 2.59 mm x 2.92 mm)

**DESCRIPTION**

The GS3018 contains Gennum's GR504 class D preamplifier chip, six capacitors and one resistor. Capacitor C1 on the hybrid, in conjunction with  $R_{MIC}$  on the GR504 chip, form a high pass filter which provides a very well regulated supply voltage for the microphone. Resistor R1, capacitor C2 and the output impedance of the microphone ( $\approx 4\text{ k}\Omega$ ) also form a high pass filter with a corner frequency of approximately 240 Hz.

Provisions have been made on the hybrid to allow the manufacturer to increase or decrease this corner frequency with the addition of a capacitor. As the class D receiver utilizes a 100 kHz clock, lower harmonics of the frequency may feed back into the system and interact with the incoming signal from the microphone. Capacitors C5 and C6 have been added to the hybrid to minimize this effect, known as "aliasing".

Blocks A and B on the GR504 are low noise inverting preamplifiers with an open loop voltage gain of typically 50 dB. Typically, the volume control potentiometer would be placed around block A, and block B used either as a Gain Trim stage or as a Telecoil amplifier. The voltage gain of these two blocks is determined by the ratio of the input resistance to the value of the feedback resistor. With 100 k $\Omega$  potentiometer used as a feedback resistor for both stages, block A would have a maximum gain of 20 dB, and block B a gain of 26 dB.

Block C is a mid-supply referenced output stage designed to drive class D receivers. It is typically capable of 670 mV peak to peak output voltage swing and 14 dB of MPO (Maximum Power Output) control with a 10 k $\Omega$  MPO potentiometer. The gain of the output stage is fixed at typically 16 dB.

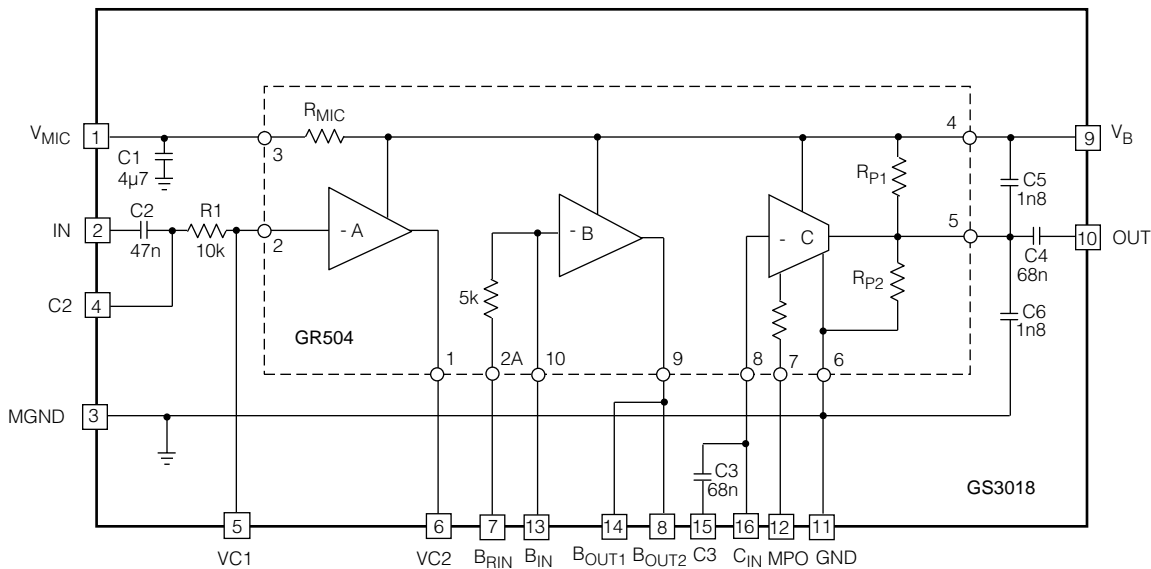

All resistors in ohms, all capacitors in farads unless otherwise stated.

**FUNCTIONAL BLOCK DIAGRAM**

## ABSOLUTE MAXIMUM RATINGS

PARAMETER	VALUE / UNITS
Supply Voltage	3 VDC
Power Dissipation	25 mW
Operating Temperature Range	-10° C to 40° C
Storage Temperature Range	-20° C to 70° C

**CAUTION**  
CLASS 1 ESD SENSITIVITY



## PAD CONNECTION

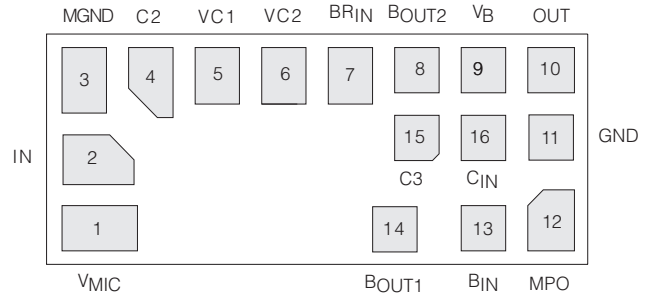

## ELECTRICAL CHARACTERISTICS

Conditions: Frequency = 1 kHz, Temperature = 25°C, Supply Voltage  $V_B = 1.3$  V

PARAMETER	SYMBOL	CONDITIONS	MIN	TYP	MAX	UNITS
Supply Current	$I_{AMP}$		165	240	315	$\mu$ A
<b>STAGE A AND B</b>						
Input Bias Voltage	$V_{BIAS}$		500	580	650	mV
Gain (pin 2 to pin 8)	GAINAB	$V_{IN} = -60$ dBV	40	44	48	dB
<b>OUTPUT STAGE</b>						
Input Bias Voltage	$V_{CIN}$		550	612	670	mV
Voltage Gain (pin 15 to pin 10)	GAINC	$V_{IN} = -50$ dBV, $R_{MPO} = 0$	14	16	18	dB
Maximum Output Level	MPO	$V_{IN} = -22$ dBV, $R_{MPO} = 0$	-14.5	-12.5	-10.5	dBV
MPO Range	$\Delta$ MPO	$V_{IN} = -22$ dBV, $R_{MPO} = 10$ K	12	14	16	dB
Gain at 10 kHz	GAIN10kHz	$V_{IN} = -55$ dBV, $R_{MPO} = 0$	0	4.5	9.0	dB

All parameters and switches remain as shown in the Test Circuit unless otherwise stated in CONDITIONS column

$V_{QX}$  - quiescent (unbias) voltage measured on the pin, (nothing connected to the pin).  $V_{PX}$  - actual voltage measured on the pin at given condition (X is pin number).

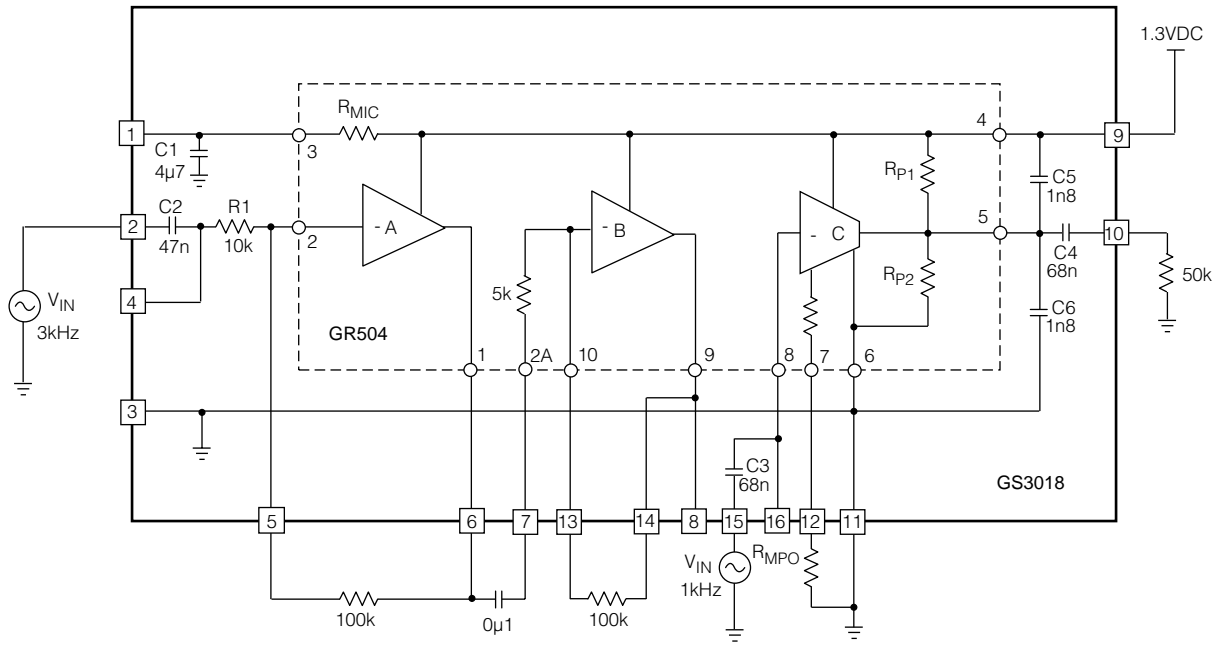

All resistors in ohms, all capacitors in farads unless otherwise stated.

Fig. 1 Production Test Circuit

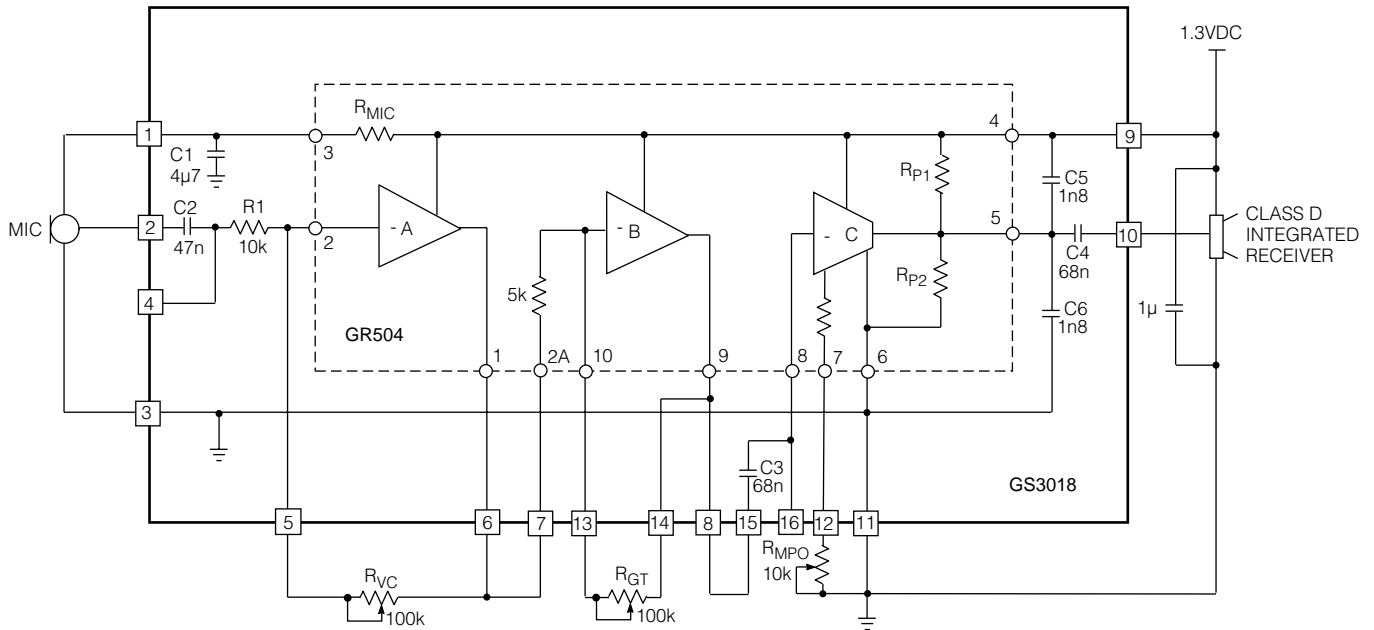

All resistors in ohms, all capacitors in farads unless otherwise stated.

Fig. 2 Typical Hearing Instrument Application

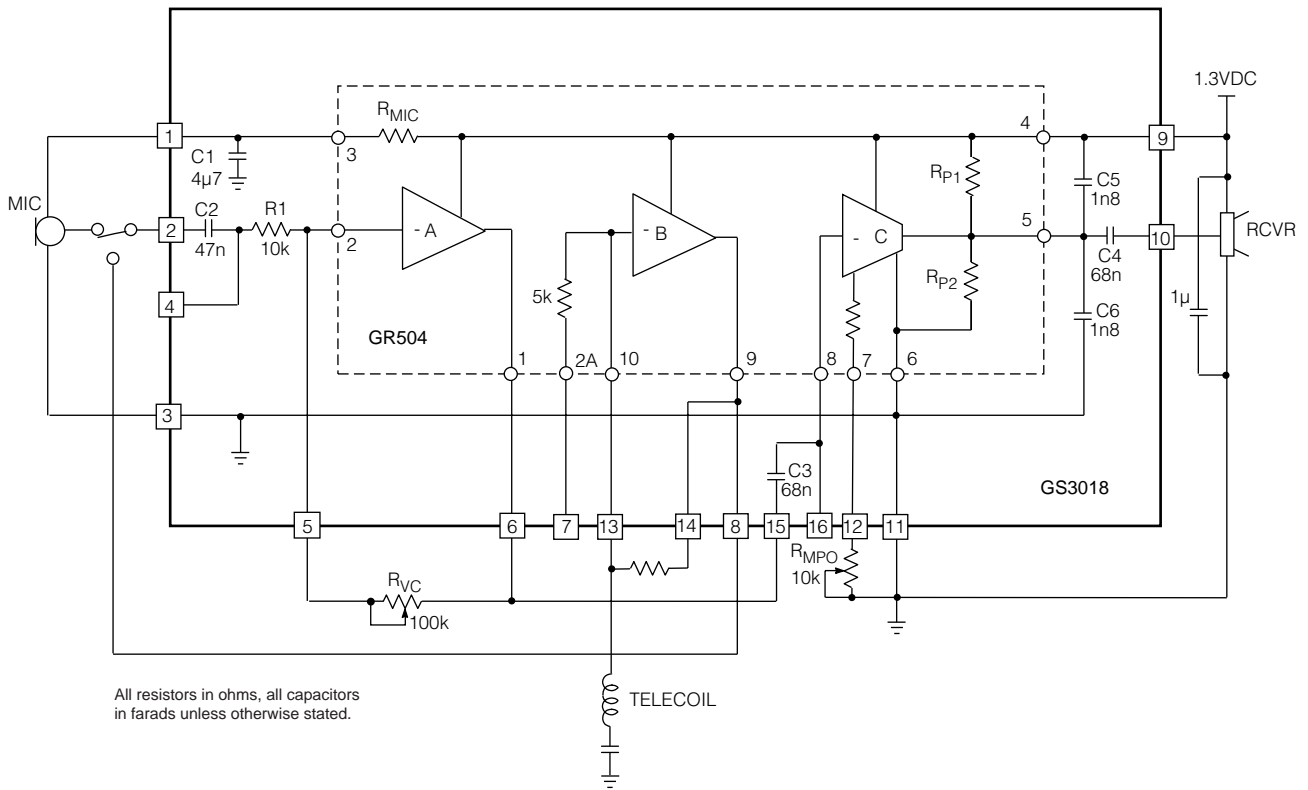

Fig. 3 Typical Application Circuit

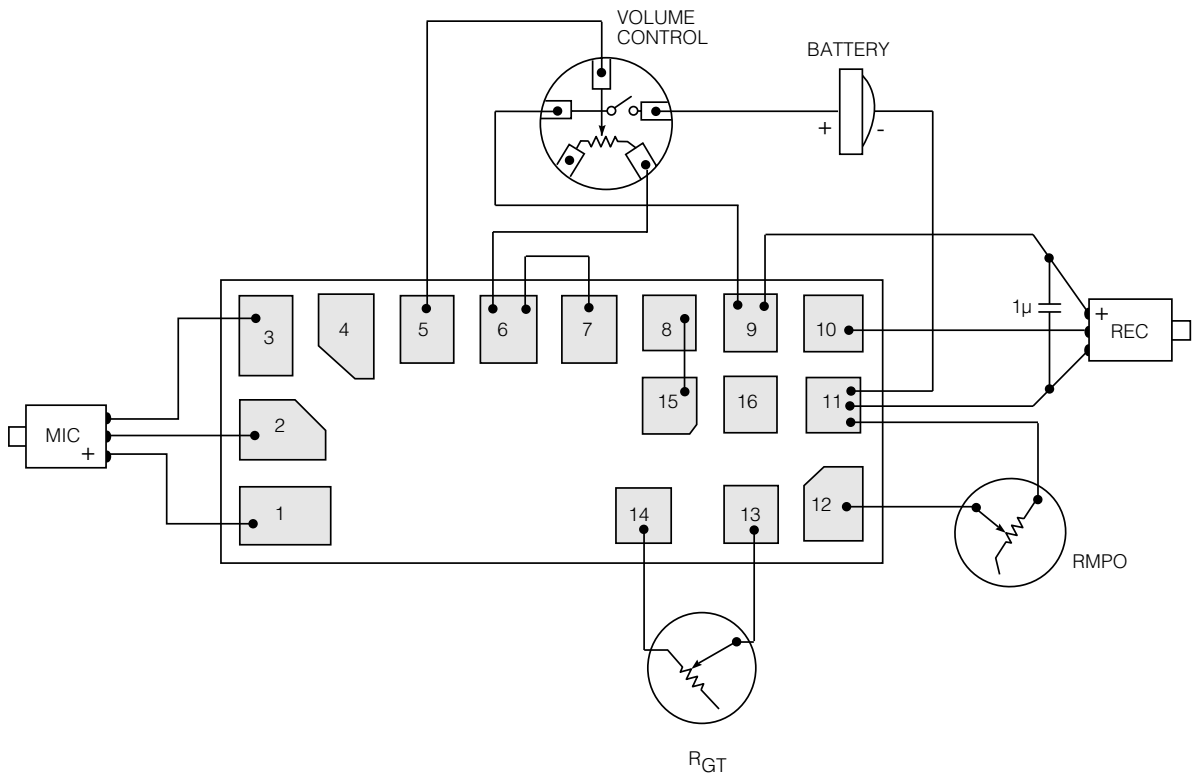

Fig. 4 Typical Assembly Diagram

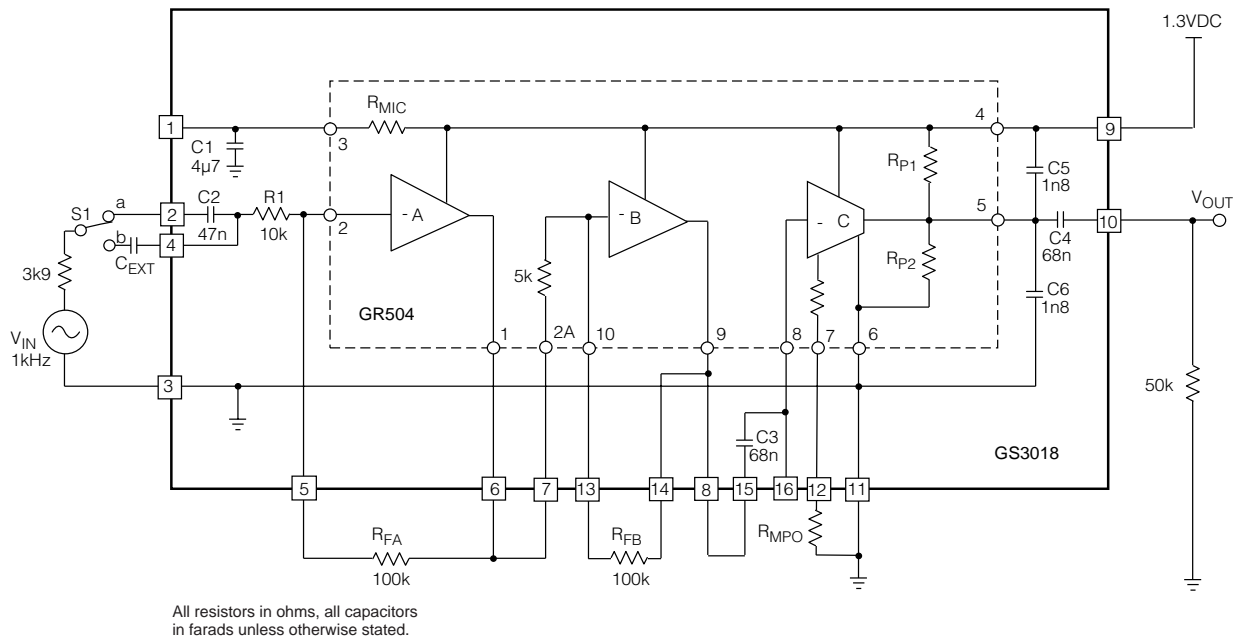

Fig. 5 Characterization Circuit  
(used to generate typical curves)

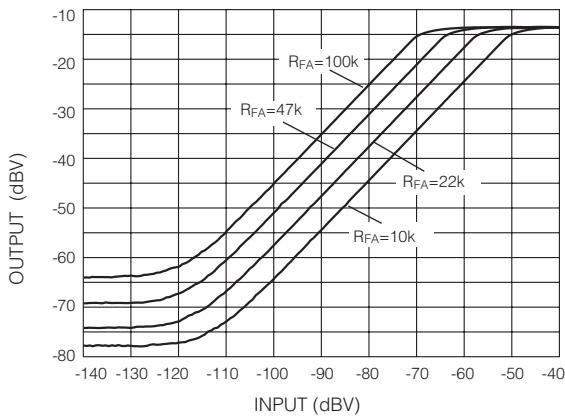

Fig. 6 Input vs Output ( $R_{MPO} = 0$ )

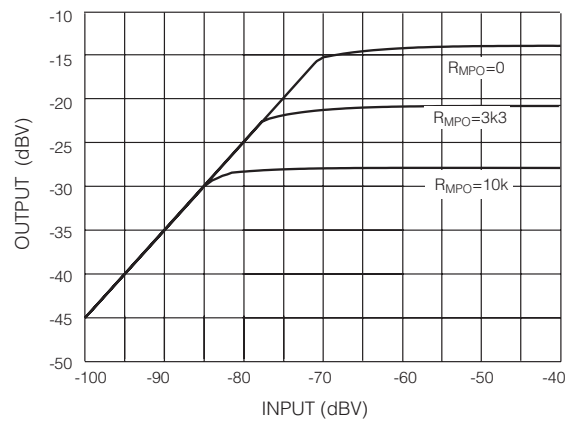

Fig. 7 Maximum Power Output vs  $R_{MPO}$

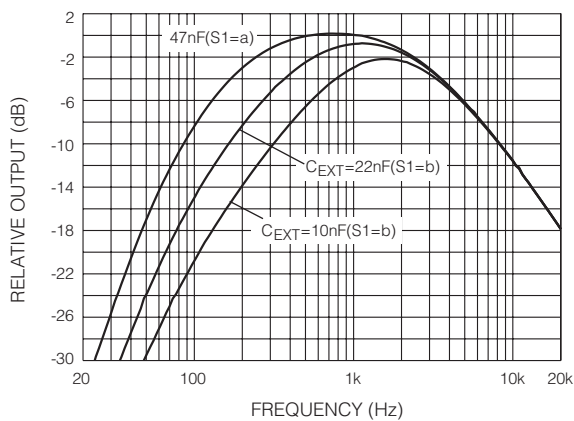

Fig. 8 Frequency Response vs  $C_{IN}$

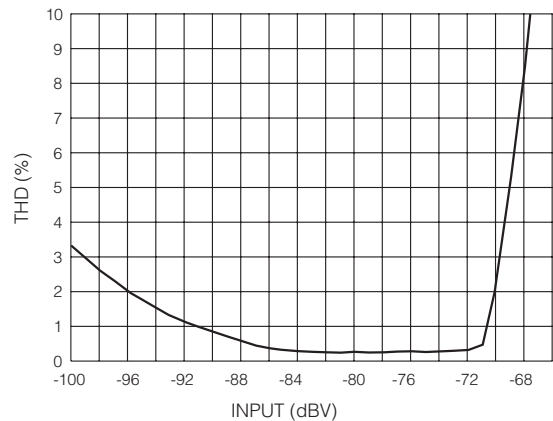
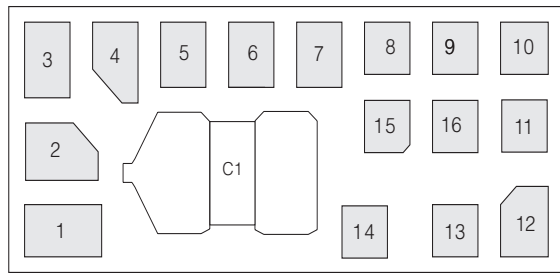
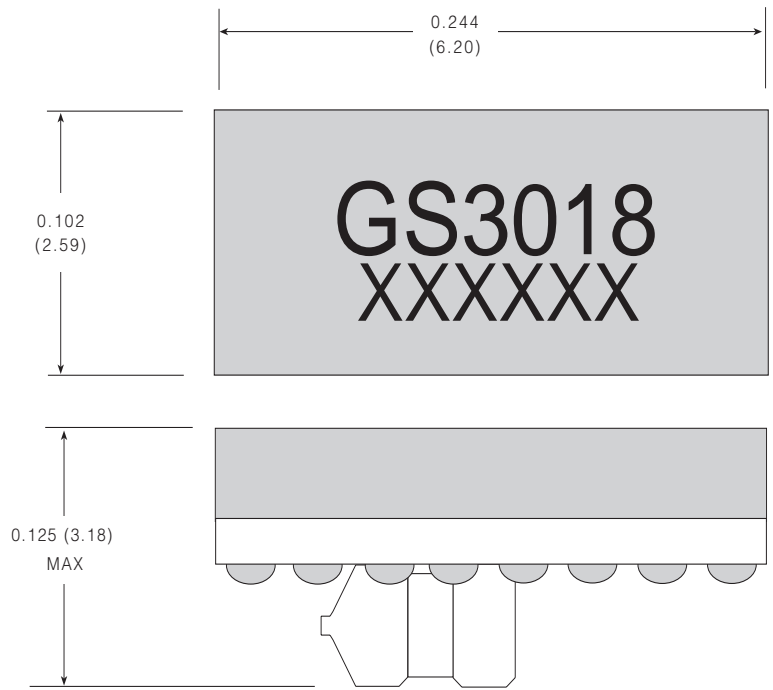

Fig. 9 THD vs Input ( $R_{FA}=100k, R_{MPO}=0$ )



Dimension units are in inches.  
 Dimensions in parenthesis are in millimetres converted from inches and include minor round-off errors.  
 1.0000 inches = 25.400 mm.  
 Smallest pad 0.020 x 0.020 (0.51 x 0.51).  
 Largest pad 0.034 x 0.020 (0.86 x 0.51).  
 Dimension tolerances  $\pm 0.003^*$  ( $\pm 0.08$ ) unless otherwise specified.  
 Pad numbers and capacitor numbers for illustration only.  
 XXXXXX - work order number.  
 This hybrid is designed for point to point manual soldering.

Fig. 9 Hybrid Layout and Dimensions

**DOCUMENT IDENTIFICATION: DATA SHEET**  
 The product is in production. Gennum reserves the right to make changes at any time to improve reliability, function or design, in order to provide the best product possible.

**REVISION NOTES:**  
 Updated to Data sheet

This datasheet has been download from:

[www.datasheetcatalog.com](http://www.datasheetcatalog.com)

Datasheets for electronics components.