

High Efficiency Selectable Current Limit Synchronous Step-Up DC/DC Converter

FEATURES

- High Efficiency (93% when $V_{IN}=2.4V$, $V_{OUT}=3.3V$, $I_{OUT}=200mA$)
- Output Current up to 500mA. ($V_{IN}=2.4V$, at $V_{OUT}=3.3V$, CLSEL=OUT)
- 20 μA Quiescent Supply Current.
- Power-Saving Shutdown Mode (0.1 μA typical).
- Internal Synchronous Rectifier (No External Diode Required).
- Selectable Current Limit for Reduced Ripple
- Low Noise , Anti-Ringing Feature.
- On-Chip Low Battery Detector.
- Low Battery Hysteresis
- Space-Saving Package: MSOP-10

APPLICATIONS

- Palmtop & Notebook Computers.
- PDAs
- Wireless Phones
- Pocket Organizers.
- Digital Cameras.
- Hand-Held Devices with 1 to 3-Cell of NiMH/NiCd Batteries.

DESCRIPTION

AIC1612 is a high efficiency step-up DC-DC converter. The start-up voltage is as low as 0.8V with operating voltage down to 0.7V. Simply consuming 20 μA of quiescent current, these devices offer a built-in synchronous rectifier that reduces size and cost by eliminating the need for an external Schottky diode and improves overall efficiency by minimizing losses.

The switching frequency can range up to 500KHz depending on the load and input voltage. The output voltage can be easily set by two external resistors from 1.8V to 5.5V, connecting FB to OUT to get 3.3V, or connecting to GND to get 5.0V. In terms of design flexibility, the peak current of internal switch is selectable (0.65A or 1.0A). AIC1612 also features a circuit that eliminates noise due to inductor ringing.

TYPICAL APPLICATION CIRCUIT

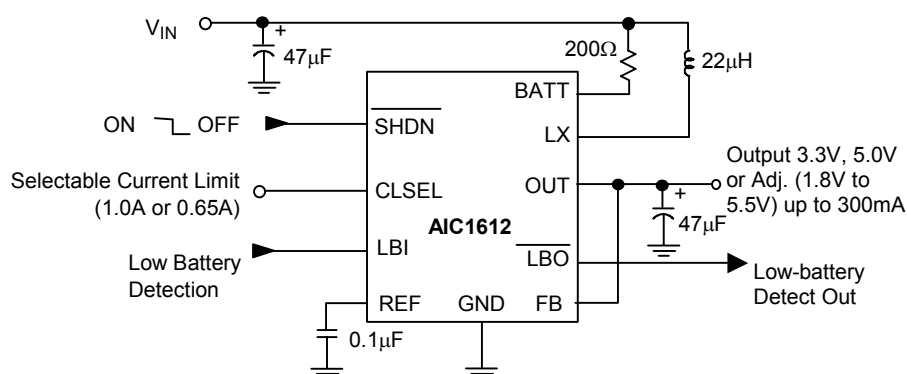

ORDERING INFORMATION

AIC1612XXXX

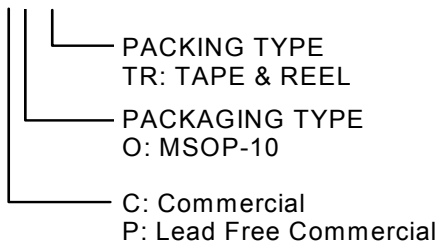

Example: AIC1612COTR
 → In MSOP-10 Package & Taping & Reel Packing Type
 AIC1612POTR
 → In MSOP-10 Lead Free Package & Taping & Reel Packing Type

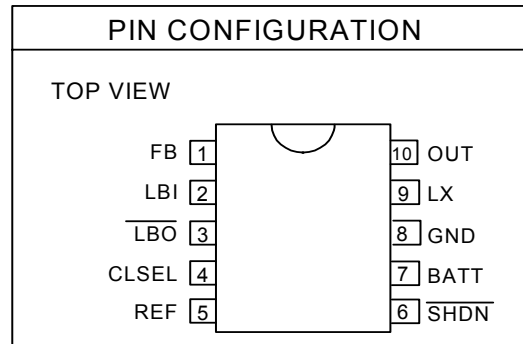

ABSOLUTE MAXIMUM RATINGS

Supply Voltage (OUT to GND)	8.0V
Switch Voltage (LX to GND)	$V_{OUT} + 0.3V$
Battery Voltage (BATT to GND)	6.0V
SHDN, LBO to GND	6.0V
LBI, REF, FB, CLSEL to GND	$V_{OUT} + 0.3V$
Switch Current (LX)	-1.5A to +1.5A
Output Current (OUT)	-1.5A to +1.5A
Operating Temperature Range	-40°C ~ +85°C
Maximum Junction Temperature	125°C
Storage Temperature Range	-65°C ~ 150°C
Lead Temperature (Soldering 10 Sec.)	260°C

Absolute Maximum Ratings are those values beyond which the life of a device may be impaired.

TEST CIRCUIT

Refer to Typical Application Circuit.

ELECTRICAL CHARACTERISTICS ($V_{IN}=2.0V$, $V_{OUT}=3.3V$, $FB=V_{OUT}$, $T_A=25^{\circ}C$, unless otherwise specified.) (Note1)

PARAMETER	TEST CONDITIONS	MIN.	TYP.	MAX.	UNIT
Minimum Input Voltage			0.7		V
Operating Voltage		1.1		5.5	V
Start-Up Voltage	$R_L=3K\Omega$ (Note2)		0.8	1.1	V
Start-Up Voltage Tempco			-2		mV/ $^{\circ}C$
Output Voltage Range	$V_{IN}<V_{OUT}$	1.8		5.5	
Output Voltage	$FB = V_{OUT}$	3.17	3.3	3.43	V
Steady State Output Current (Note3)	$FB=OUT$ $(V_{OUT} = 3.3V)$	$CLSEL=OUT$	300	350	mA
		$CLSEL=GND$	150	300	
	$FB=GND$ $(V_{OUT} = 5.0V)$	$CLSEL=OUT$	180	230	
		$CLSEL=GND$	90	160	
Reference Voltage	$I_{REF} = 0$	1.199	1.23	1.261	V
Reference Voltage Tempco			0.024		mV/ $^{\circ}C$
Reference Load Regulation	$I_{REF} = 0$ to $100\mu A$		10	30	mV
Reference Line Regulation	$V_{OUT} = 1.8V$ to $5.5V$		5	10	mV/V
FB , LBI Input Threshold		1.199	1.23	1.261	V
Internal switch On-Resistance	$I_{LX} = 100mA$		0.3	0.6	Ω
LX Switch Current Limit	$CLSEL=OUT$	0.80	1.0	1.25	A
	$CLSEL=GND$	0.50	0.65	0.85	
LX Leakage Current	$V_{LX}=0V\sim 4V$; $V_{OUT}=4V$		0.05	1	μA
Operating Current into OUT (Note4)	$V_{FB} = 1.4V$, $V_{OUT} = 3.3V$		20	35	μA
Shutdown Current into OUT	$\overline{SHDN} = GND$		0.1	1	μA
Efficiency	$V_{OUT}= 3.3V$, $I_{LOAD} = 200mA$		90		%
	$V_{OUT} = 2V$, $I_{LOAD} = 1mA$		85		

ELECTRICAL CHARACTERISTICS (Continued)

PARAMETER	TEST CONDITIONS	MIN.	TYP.	MAX.	UNIT
LX Switch On-Time	$V_{FB} = 1V, V_{OUT} = 3.3V$	2	4	7	μS
LX Switch Off-Time	$V_{FB} = 1V, V_{OUT} = 3.3V$	0.6	0.9	1.4	μS
FB Input Current	$V_{FB} = 1.4V$		0.03	50	nA
LBI Input Current	$V_{LBI} = 1.4V$		1	50	nA
CLSEL Input Current	CLSEL = OUT		1.4	3	μA
SHDN Input Current	$V_{SHDN} = 0$ or V_{OUT}		0.07	50	nA
LBO Low Output Voltage	$V_{LBI} = 0, I_{SINK} = 1mA$		0.2	0.4	μA
LBO Off Leakage Current	$V_{LBO} = 5.5V, V_{LBI} = 5.5V$		0.07	1	
LBI Hysteresis			50		mV
Damping Switch Resistance	$V_{BATT} = 2V$		50	100	Ω
SHDN Input Voltage	V_{IL}			$0.2V_{OUT}$	V
	V_{IH}	$0.8V_{OUT}$			
CLSEL Input Voltage	V_{IL}			$0.2V_{OUT}$	V
	V_{IH}	$0.8V_{OUT}$			

Note 1: Specifications are production tested at $T_A=25^\circ C$. Specifications over the $-40^\circ C$ to $85^\circ C$ operating temperature range are assured by design, characterization and correlation with Statistical Quality Controls (SQC).

Note 2: Start-up voltage operation is guaranteed without the addition of an external Schottky diode between the input and output.

Note 3: Steady-state output current indicates that the device maintains output voltage regulation under load.

Note 4: Device is bootstrapped (power to the IC comes from OUT). This correlates directly with the actual battery supply.

TYPICAL PERFORMANCE CHARACTERISTICS

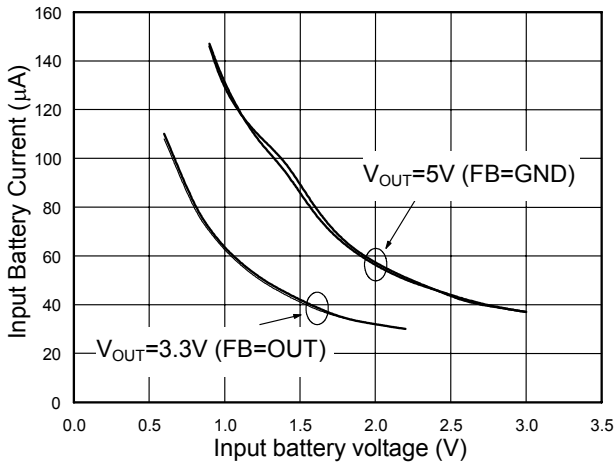

Fig. 1 No-Load Battery Current vs. Input Battery

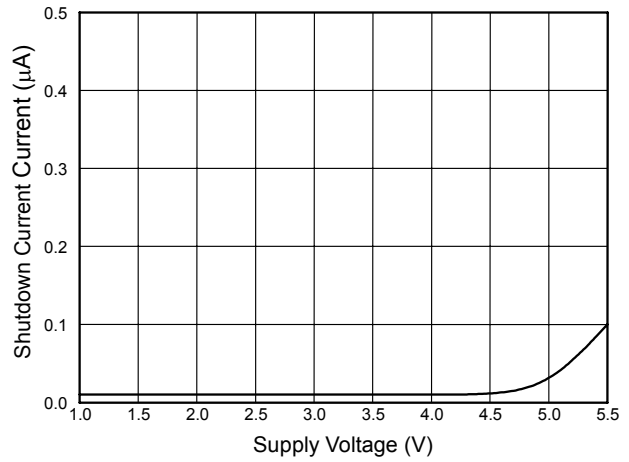

Fig. 2 Shutdown Current vs. Supply Voltage

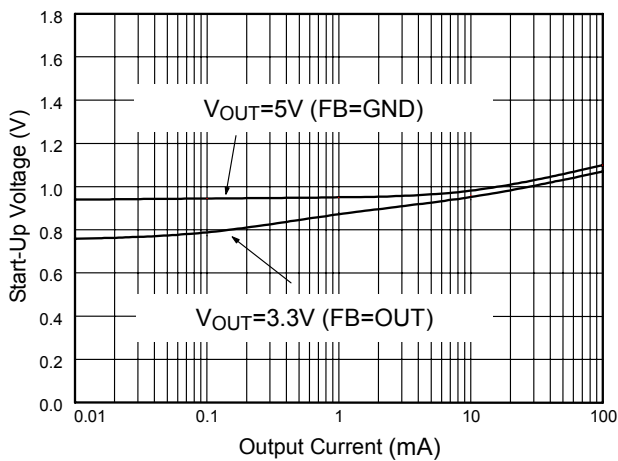

Fig. 3 Start-Up Voltage vs. Output Current

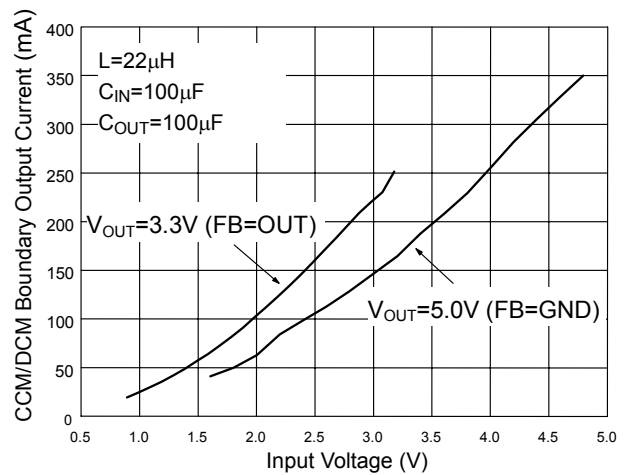

Fig. 4 Turning Point between CCM & DCM

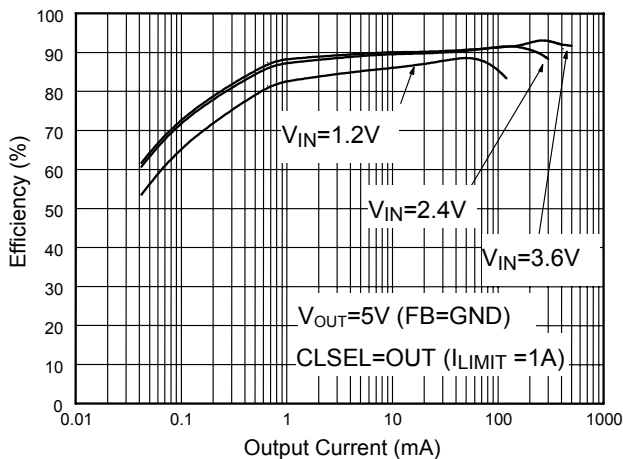

Fig. 5 Efficiency vs. Output Current (ref. to Fig.35)

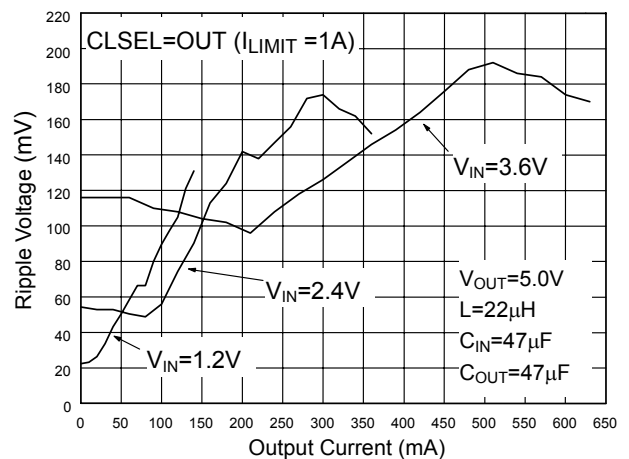

Fig. 6 Ripple Voltage (ref. to Fig.35)

TYPICAL PERFORMANCE CHARACTERISTICS (Continued)

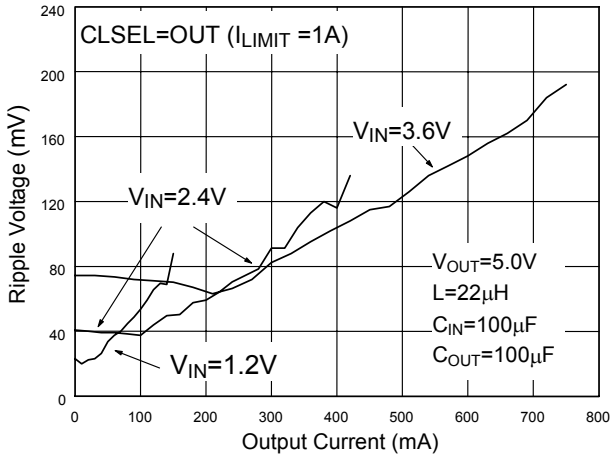

Fig. 7 Ripple Voltage (ref. to Fig.35)

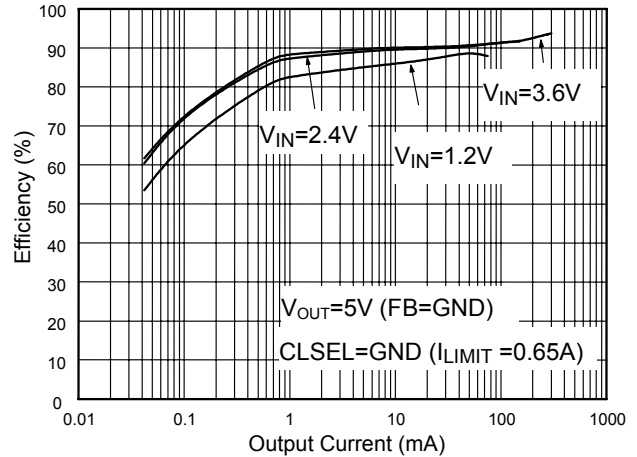

Fig. 8 Efficiency vs. Output Current (ref. to Fig.35)

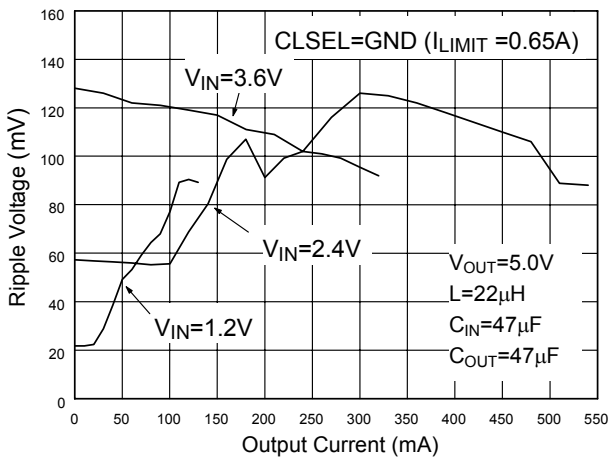

Fig. 9 Ripple Voltage (ref. to Fig.35)

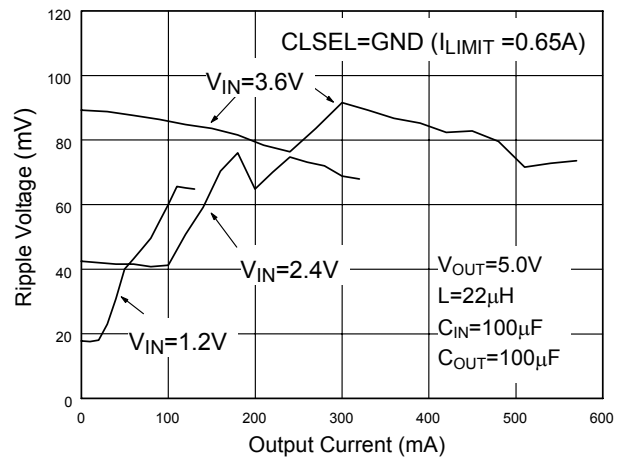

Fig. 10 Ripple Voltage (ref. to Fig.35)

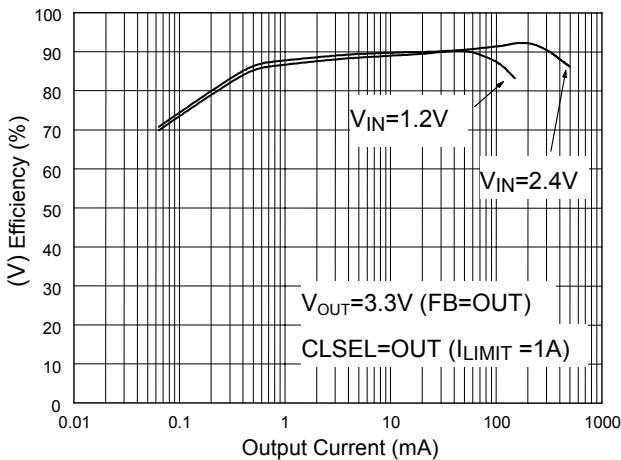

Fig. 11 Efficiency vs. Output Current (ref. to Fig.34)

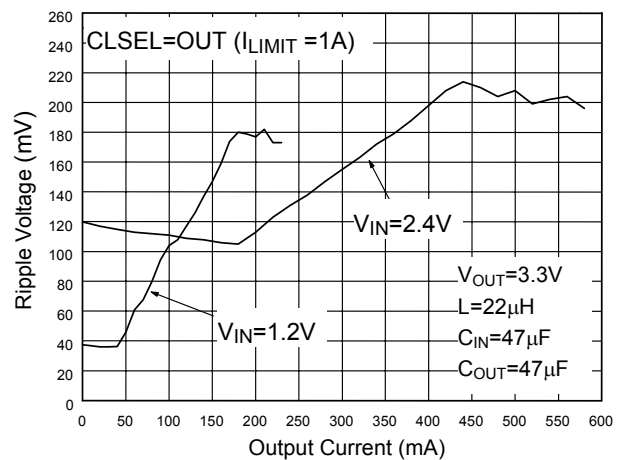

Fig. 12 Ripple Voltage (ref. to Fig.34)

TYPICAL PERFORMANCE CHARACTERISTICS (Continued)

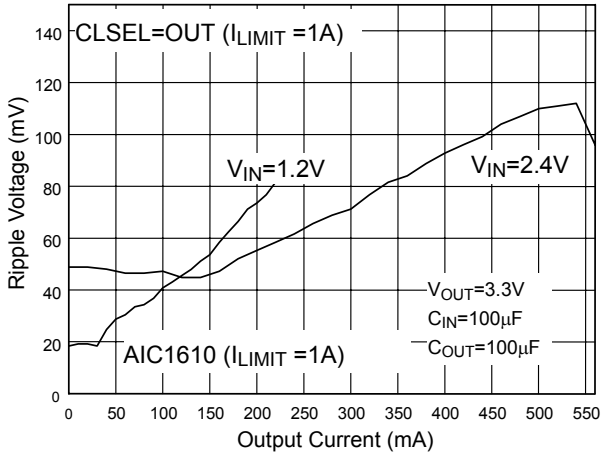

Fig. 13 Ripple Voltage (ref. to Fig.34)

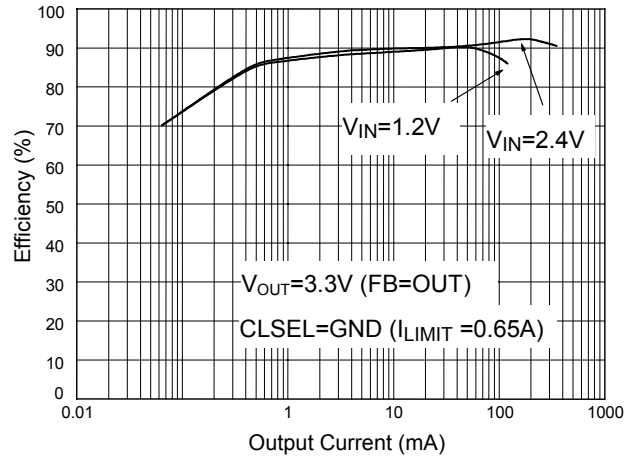

Fig. 14 Efficiency vs. Output Current (ref. to Fig.34)

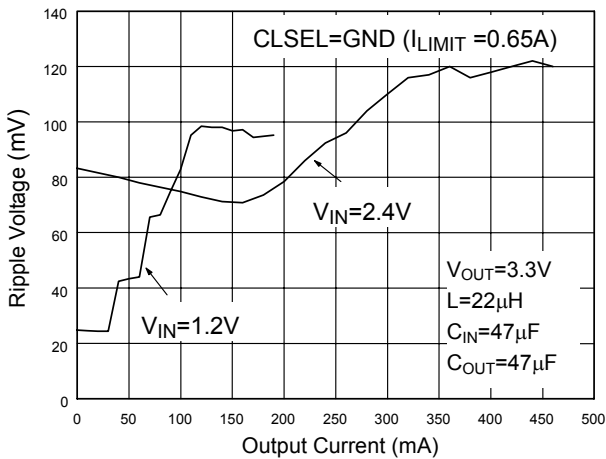

Fig. 15 Ripple Voltage (ref. to Fig.34)

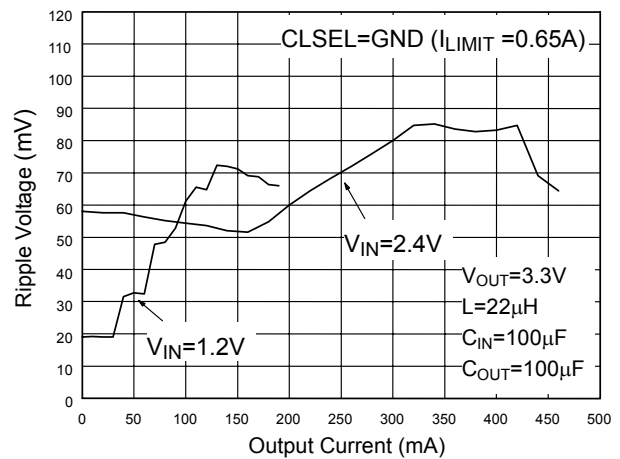

Fig. 16 Ripple Voltage (ref. to Fig.34)

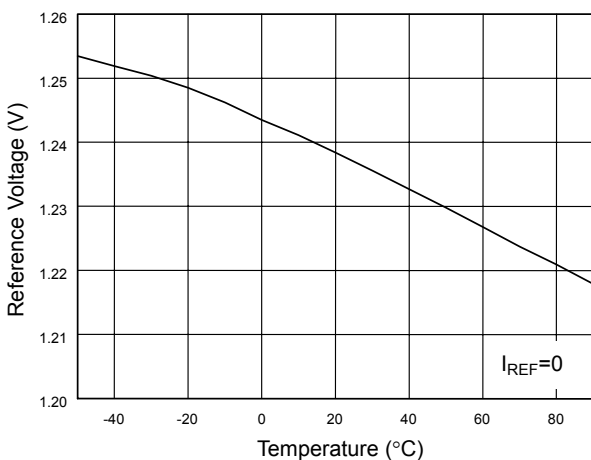

Fig. 17 Reference Voltage vs. Temperature

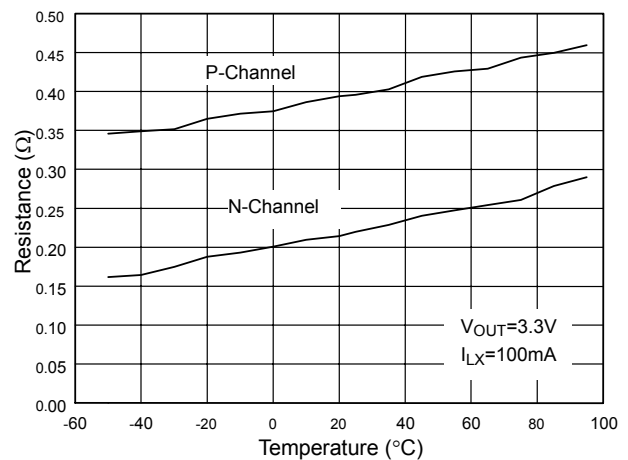

Fig. 18 Switch Resistance vs. Temperature

TYPICAL PERFORMANCE CHARACTERISTICS (Continued)

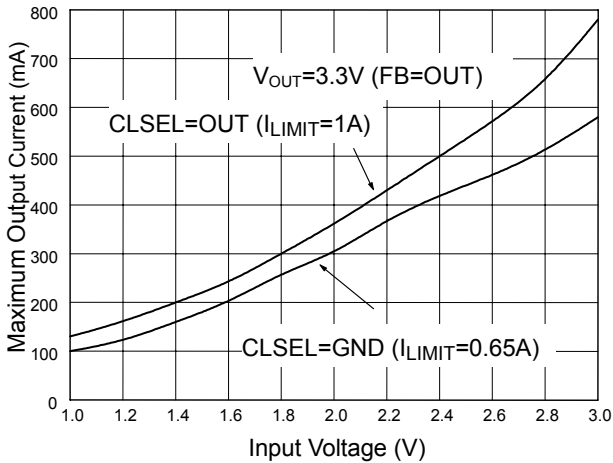

Fig. 19 Maximum Output Current vs. Input Voltage

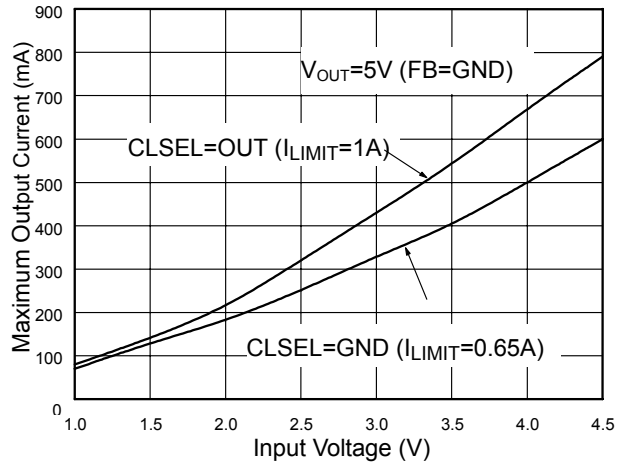

Fig. 20 Maximum Output Current vs. Input Voltage

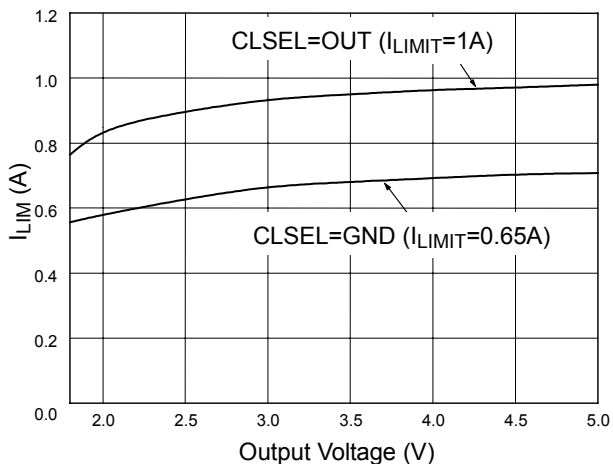

Fig. 21 Inductor Current vs. Output Voltage

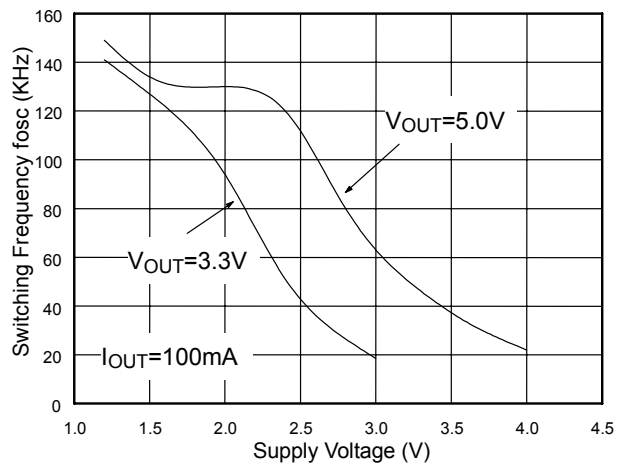

Fig. 22 Switching Frequency vs. Supply Voltage

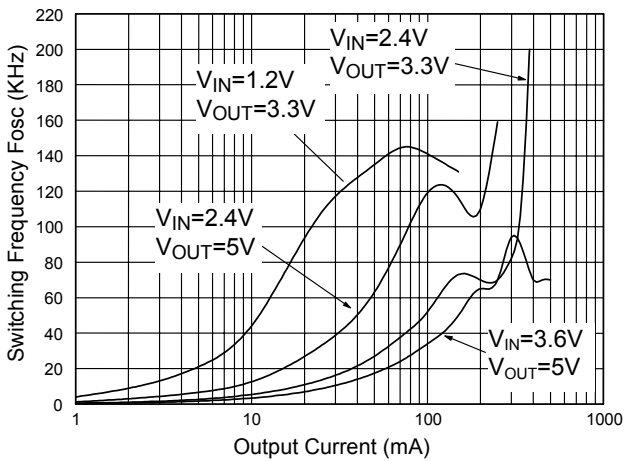

Fig. 23 Switching Frequency vs. Output Current

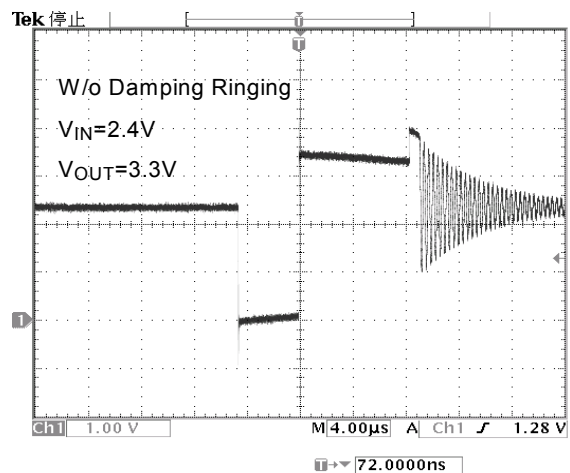

Fig. 24 Without Damping Ringing Function

TYPICAL PERFORMANCE CHARACTERISTICS (Continued)

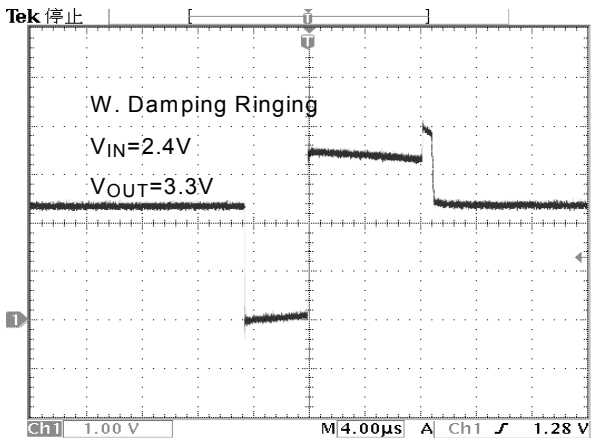

Fig. 25 With Damping Ringing Function

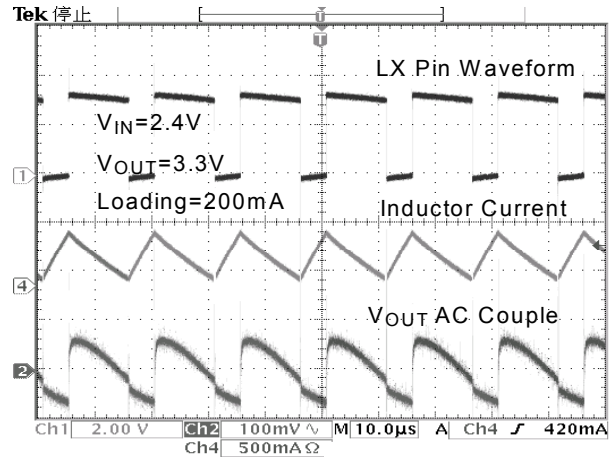

Fig. 26 Heavy Load Waveform

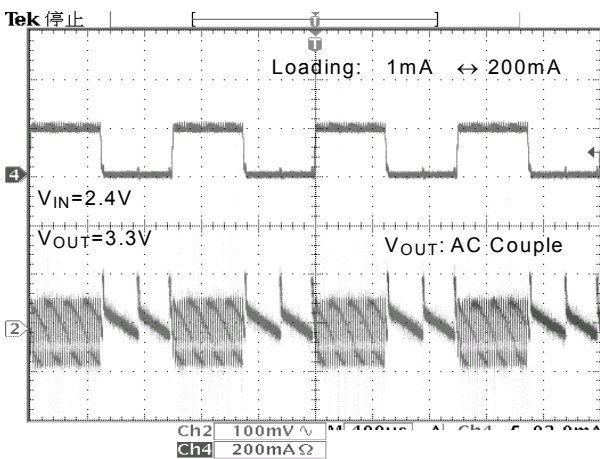

Fig. 27 Load Transient Response

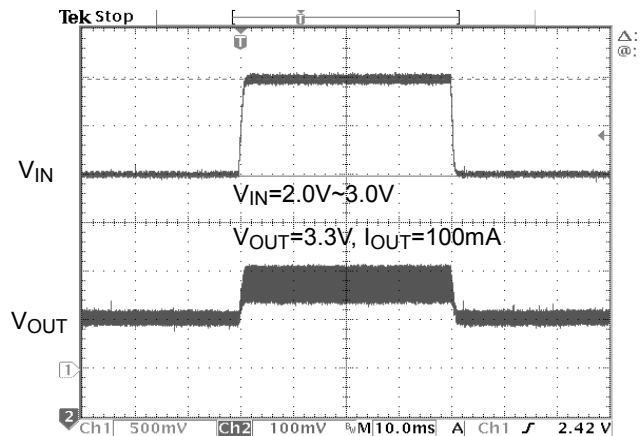

Fig. 28 Line Transient Response

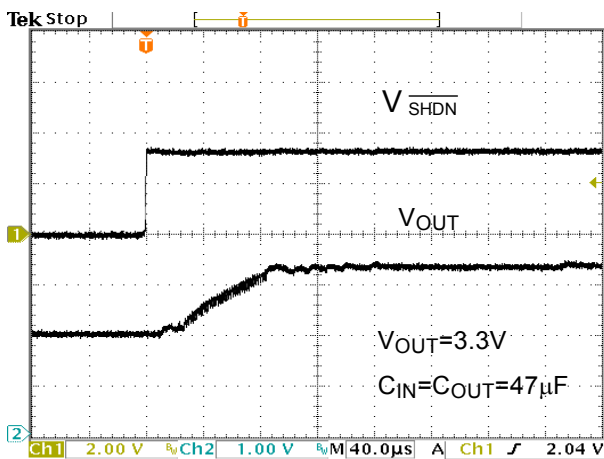

Fig. 29 Exiting Shutdown

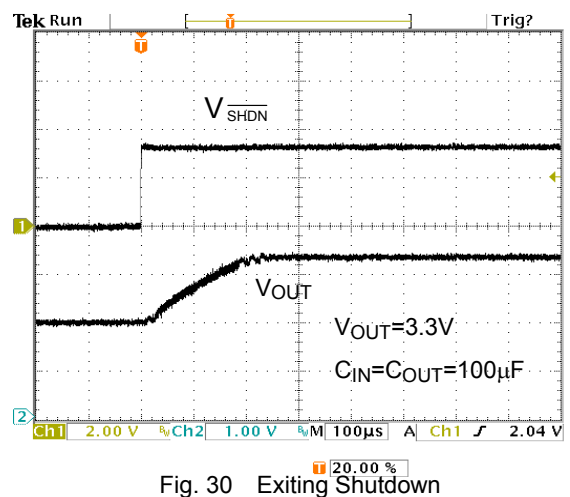

Fig. 30 Exiting Shutdown

TYPICAL PERFORMANCE CHARACTERISTICS (Continued)

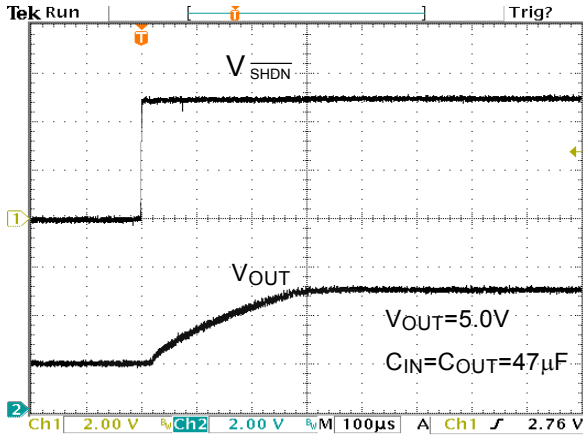

Fig. 31 Exiting Shutdown

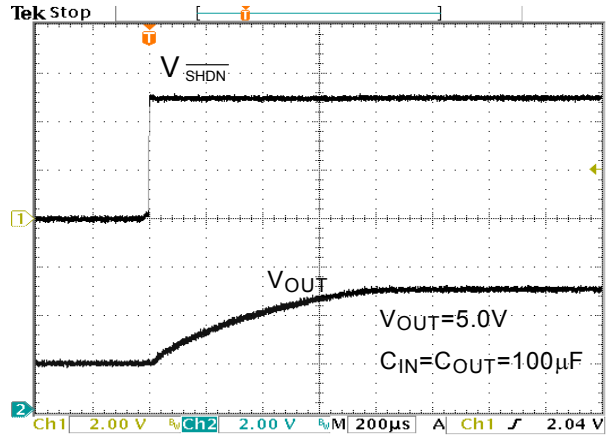
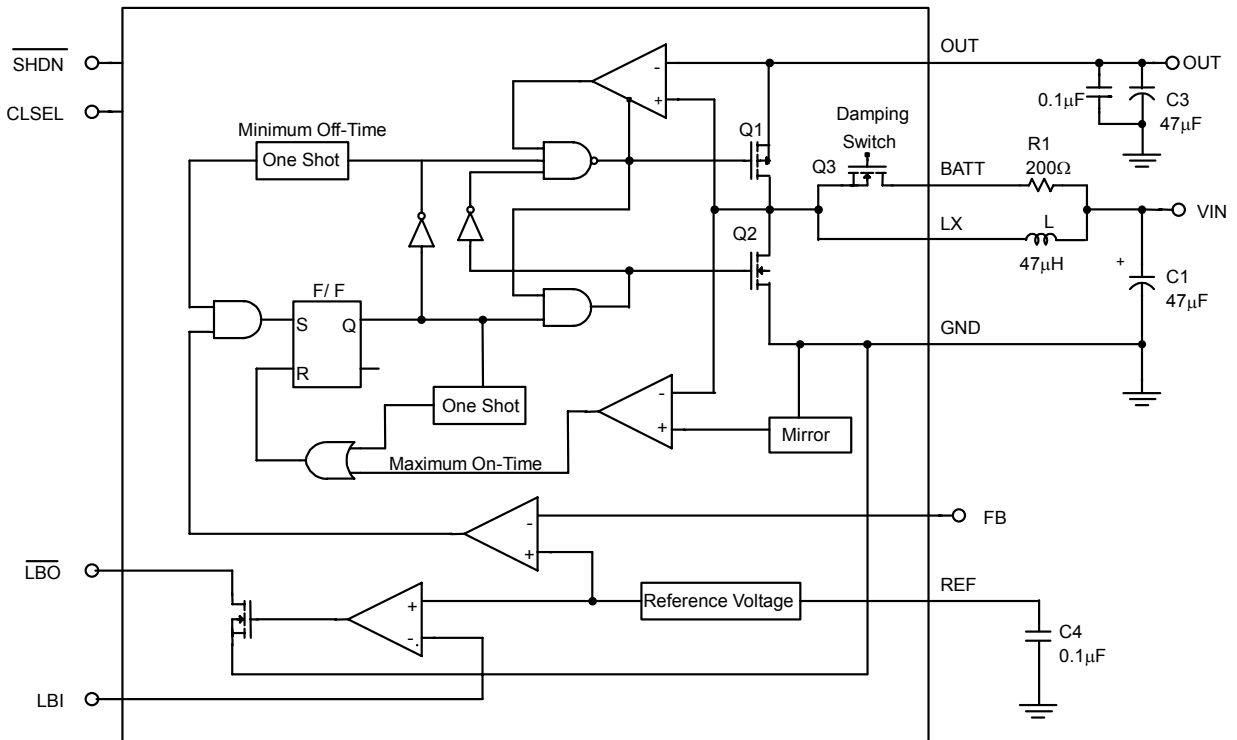

Fig. 32 Exiting Shutdown

BLOCK DIAGRAM



■ PIN DESCRIPTIONS

- PIN 1: FB- Connecting to OUT to get +3.3V output, connecting to GND to get +5.0V output, or using a resistor network to set output voltage ranging from +1.8V to +5.5V.
- PIN 2: LBI- Low-Battery comparator input internally sets at +1.23V to trip.
- PIN 3: $\overline{\text{LBO}}$ - Open-drain low battery comparator output. Output is low when VLBI is <1.23V. LBO is high impedance during shutdown.
- PIN 4: CLSEL- Current-limit selects input. CLSEL=OUT sets the current limit to 1.0A. CLSEL=GND sets the current limit to 0.65A.
- PIN 5: REF- 1.23V reference voltage. Bypass with a 0.1 μ F capacitor.
- PIN 6: $\overline{\text{SHDN}}$ - Shutdown input. High=operating, low=shutdown.
- PIN 7: BATT- Battery input and damping switch connection. If damping switch is unused, leave BATT unconnected.
- PIN 8: GND- Ground.
- PIN 9: LX- N-channel and P-channel power MOSFET drain.
- PIN 10: OUT- Power output. OUT provides bootstrap power to the IC.

■ APPLICATION INFORMATION

Overview

AIC1612 is a high efficiency, step-up DC-DC converter, designed to feature a built-in synchronous rectifier, which reduces size and cost by eliminating the need for an external Schottky diode. The start-up voltage of AIC1612 is as low as 0.8V and it operates with an input voltage down to 0.7V. Quiescent supply current is only 20 μ A. In addition, AIC1612 features a circuit that eliminates inductor ringing to reduce noise. The internal P-MOSFET on-resistance is typically 0.3 Ω to improve overall efficiency by minimizing AC losses. The output voltage can be easily set by two external resistors from 1.8V to 5.5V, connecting FB to OUT to get 3.3V, or connecting to GND to get 5.0V. CLSEL pin of AIC1612 offers a selectable current limit (1.0A or 0.65A). The lower current limit allows the use of a physically smaller inductor in space-sensitive applications.

PFM Control Scheme

The key feature of AIC1612 is a unique minimum-off-time, constant-on-time, current-limited, pulse-frequency-modulation (PFM) control scheme (see BLOCK DIAGRAM) with ultra-low quiescent current. The peak current of the internal N-MOSFET power

switch is selectable. The switch frequency depends on either loading condition or input voltage, and can range up to 500KHz. It is governed by a pair of one-shots that set a minimum off-time (1 μ S) and a maximum on-time (4 μ S).

Synchronous Rectification

Using the internal synchronous rectifier eliminates the need for an external Schottky diode. Therefore, the cost and board space are reduced. During the cycle of off-time, P-MOSFET turns on and shuts N-MOSFET off. Due to the low turn-on resistance of MOSFET, synchronous rectifier significantly improves efficiency without an additional external Schottky diode. Thus, the conversion efficiency can be as high as 93%.

Reference Voltage

The reference voltage (REF) is nominally 1.23V for excellent T.C. performance. In addition, REF pin can source up to 100 μ A to external circuit with good load regulation (<10mV). A bypass capacitor of 0.1 μ F is required for proper operation and good performance.

Shutdown

The whole circuit is shutdown when $\overline{V_{SHDN}}$ is low. At shutdown mode, the current can flow from battery to output due to the body diode of P-MOSFET. V_{OUT} falls to approximately $V_{in}-0.6V$ and LX remains high impedance. The capacitance and load at OUT determine the rate at which V_{OUT} decays. Shutdown can be pulled as high as 6V, regardless of the voltage at OUT.

Current Limit Select Pin

AIC1612 allows a selectable inductor current limit of either 1.0A or 0.65A. The flexibility contributes to designs for higher current or smaller applications. CLSEL draws 1.4 μ A when connecting to OUT.

BATT/Damping Switch

AIC1612 is designed with an internal damping switch (Fig.33) to reduce ringing at LX. The damping switch supplies a path to quickly dissipate the energy stored in inductor and reduces the ringing at LX. Damping LX ringing does not reduce V_{OUT} ripple, but does reduce EMI. $R1=200\Omega$ works well for most applications while reducing efficiency by only 1%. Larger R1 value provides less damping, but less impact on efficiency. In principle, lower value of R1 is needed to fully damp LX when V_{OUT} / V_{IN} ratio is high.

Selecting the Output Voltage

V_{OUT} can be simply set to 3.3V/5.0V by connecting FB pin to OUT/GND due to the use of internal resistor divider in the IC (Fig.34 and Fig.35). In order to adjust output voltage, a resistor divider is connected to V_{OUT} , FB, GND (Fig.36). V_{out} can be calculated by the following equation:

$$R5=R6 [(V_{OUT} / V_{REF}) - 1] \dots\dots\dots(1)$$

Where $V_{REF} = 1.23V$ and V_{OUT} ranging from 1.8V to 5.5V. The recommended R6 is 240K Ω .

Low-Battery Detection

AIC1612 contains an on-chip comparator with 50mV internal hysteresis (REF, REF+50mV) for low battery detection. If the voltage at LBI falls below the internal reference voltage, LBO (an open-drain output) sinks current to GND.

Component Selection

1. Inductor Selection

An inductor value of 22 μ H performs well in most applications. The AIC1612 also works with inductors in the 10 μ H to 47 μ H range. An inductor with higher peak inductor current tends a higher output voltage ripple ($I_{PEAK} \times$ output filter capacitor ESR). The inductor's DC resistance significantly affects efficiency. We can calculate the maximum output current as follows:

$$I_{OUT(MAX)} = \frac{V_{IN}}{V_{OUT}} \left[I_{LIM} - t_{OFF} \left(\frac{V_{OUT} - V_{IN}}{2 \times L} \right) \right] \eta \dots\dots\dots(2)$$

where $I_{OUT(MAX)}$ =maximum output current in amps

- V_{IN} =input voltage
- L =inductor value in μ H
- η =efficiency (typically 0.9)
- t_{OFF} =LX switch' off-time in μ S
- I_{LIM} =1.0A or 0.65A

2. Capacitor Selection

The output voltage ripple relates with the peak inductor current and the output capacitor ESR. Besides output ripple voltage, the output ripple current also needs to be concerned. A filter capacitor with low ESR is helpful to the efficiency and steady state output current of AIC1612. Therefore NIPPON tantalum capacitor MCM series with 100 μ F/6V is recommended. A smaller capacitor (down to 47 μ F with higher ESR) is acceptable for light loads or in applications that can tolerate higher output ripple.

PCB Layout and Grounding

Since AIC1612's switching frequency can range up to 500kHz, it makes AIC1612 become very sensitive. So careful printed circuit layout is important for minimizing ground bounce and noise. IC's OUT pin should be as clear as possible. And the GND pin should be placed close to the ground plane. Keep the IC's GND pin and the ground leads of the input and output filter capacitors less than 0.2in (5mm) apart. In addition, keep all connection to the FB and LX pins as short as possible. In particular, when using external feedback resistors, locate them as close to the FB as possible. To maximize output pow-

power and efficiency and minimize output ripple voltage, use a ground plane and solder the IC's GND directly to the ground plane. Fig.37 to 39 are the recommended layout diagrams.

Ripple Voltage Reduction

Two or three parallel output capacitors can significantly improve output ripple voltage of AIC1612. The addition of an extra input capacitor results in a stable output voltage. Fig.40 shows the application circuit with the above features. Fig. 41 to 48 are the performances of Fig.40.

APPLICATION EXAMPLES

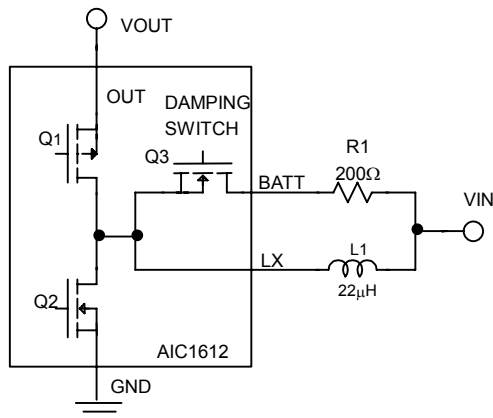
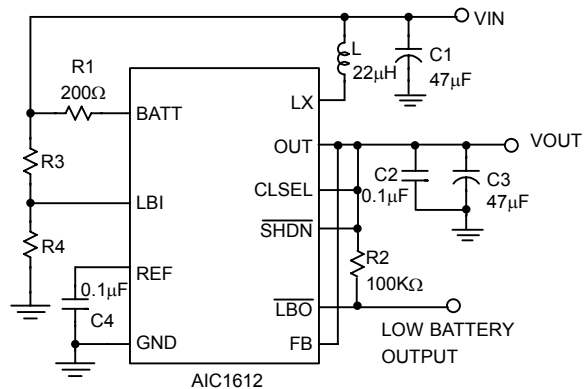
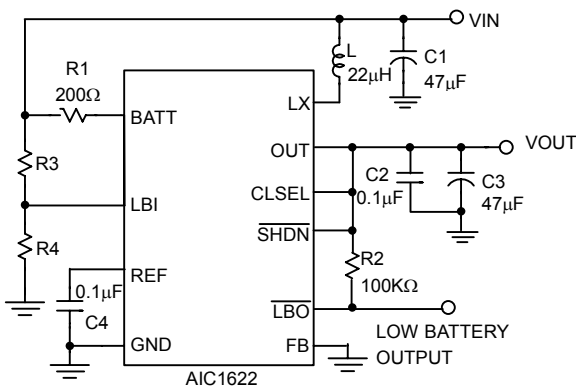

Fig.33 Simplified Damping Switch Diagram



L: TDK SLF7045T-220MR90
C1, C3: NIPPON Tantalum Capacitor 6MCM476MB2TER

Fig.34 $V_{OUT} = 3.3V$ Application Circuit.



L: TDK SLF7045T-220MR90
C1, C3: NIPPON Tantalum Capacitor 6MCM476MB2TER

Fig.35 $V_{OUT} = 5.0V$ Application Circuit.

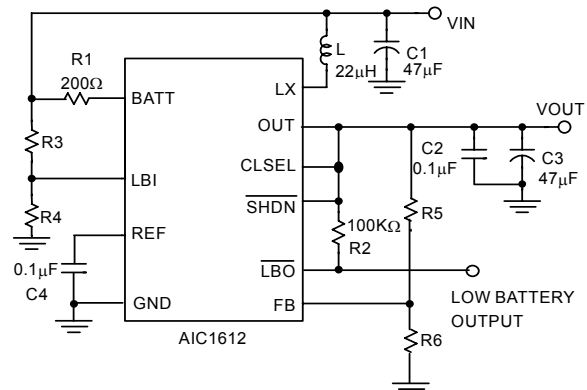

L: TDK SLF7045T-220MR90
C1, C3: NIPPON Tantalum Capacitor 6MCM476MB2TER
 $V_{OUT} = V_{REF} * (1 + R5/R6)$

Fig.36 An Adjustable Output Application Circuit

■ APPLICATION EXAMPLES (Continued)

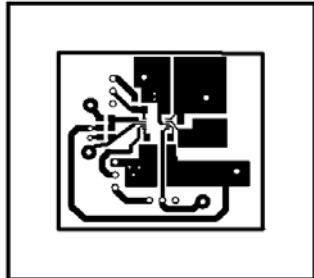

Fig.37 Top layer

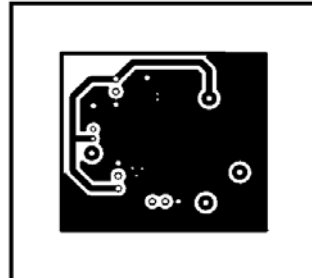

Fig.38 Bottom layer

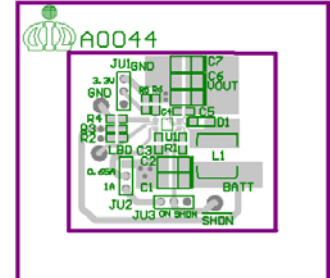

Fig.39 Placement

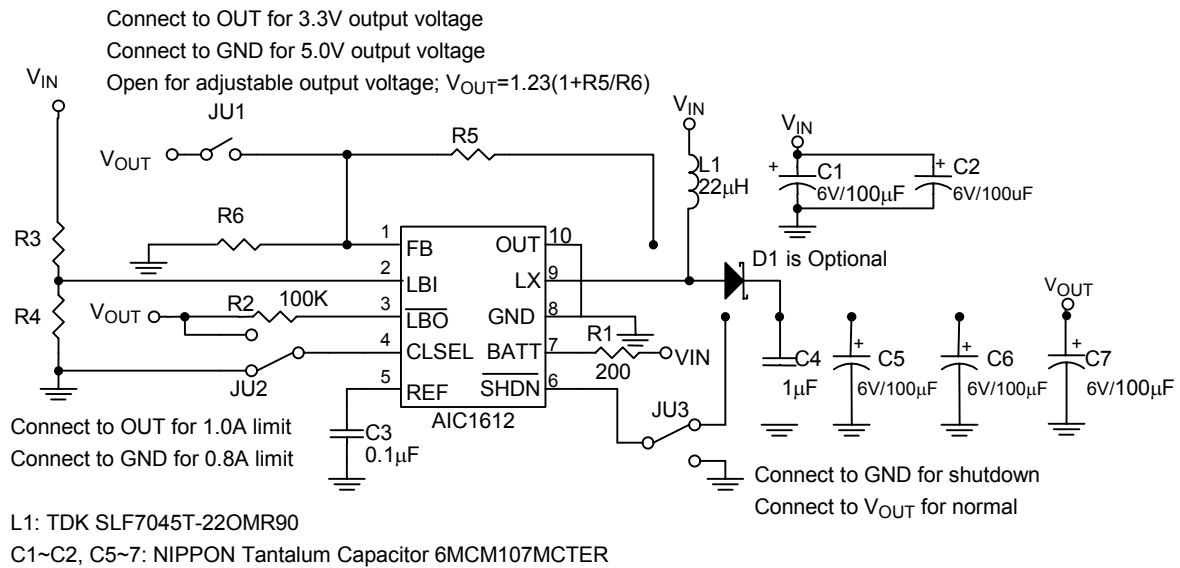

Fig.40 AIC1612 Application Circuit with Small Ripple Voltage

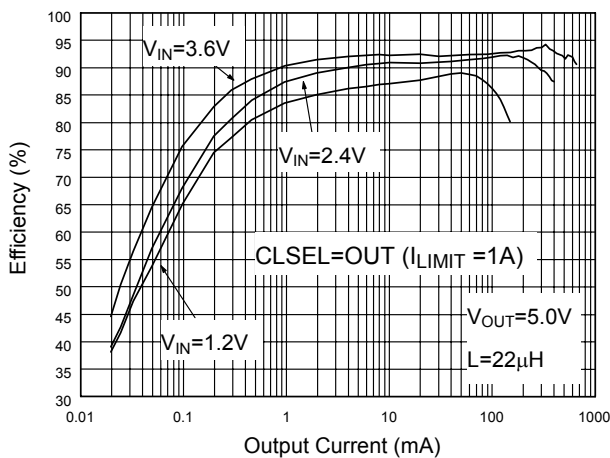

Fig. 41 Efficiency (ref. to Fig.40)

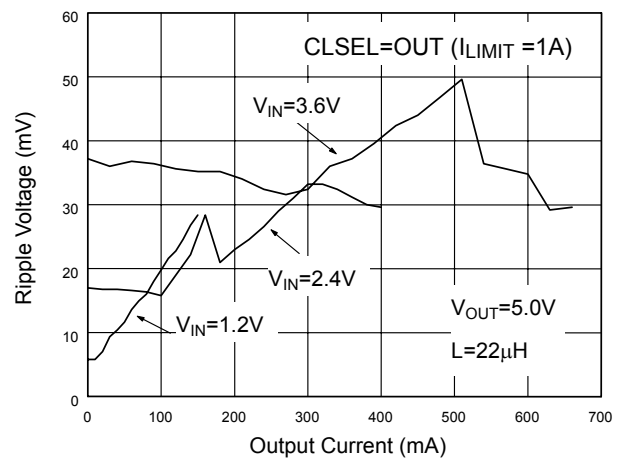

Fig. 42 Ripple Voltage (ref. to Fig.40)

APPLICATION EXAMPLES (Continued)

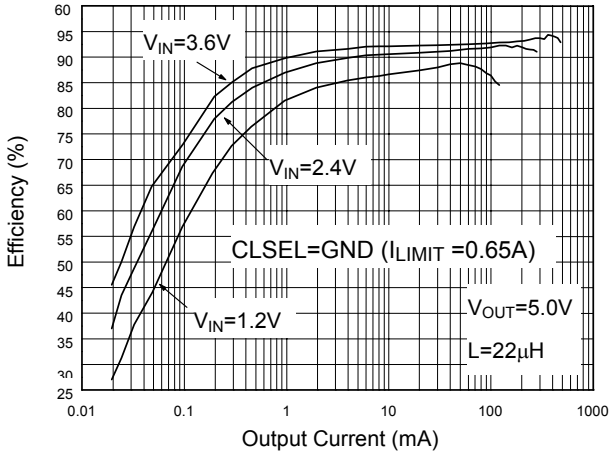

Fig. 43 Efficiency (ref. to Fig.40)

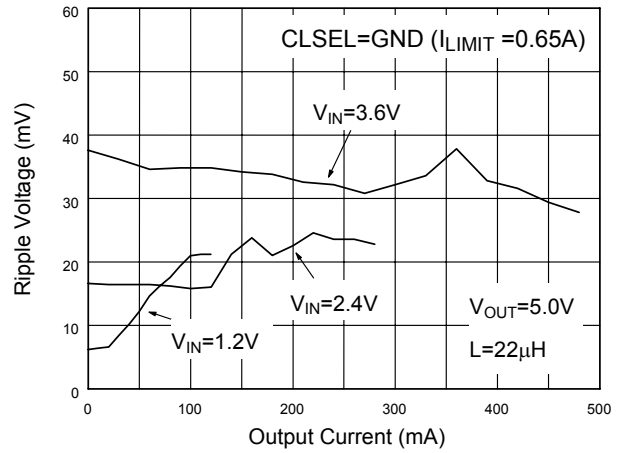

Fig. 44 Ripple Voltage (ref. to Fig.40)

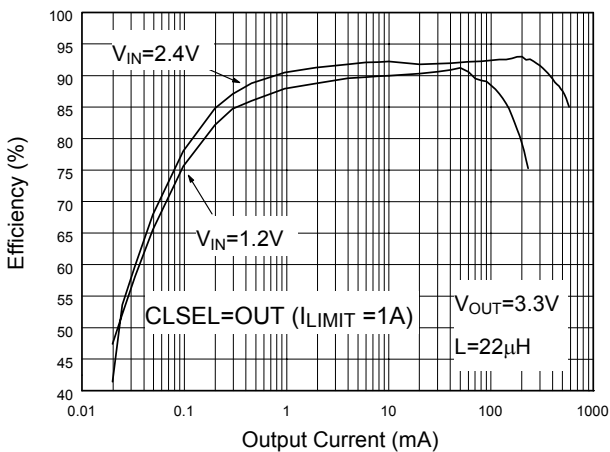

Fig. 45 Efficiency (ref. to Fig.40)

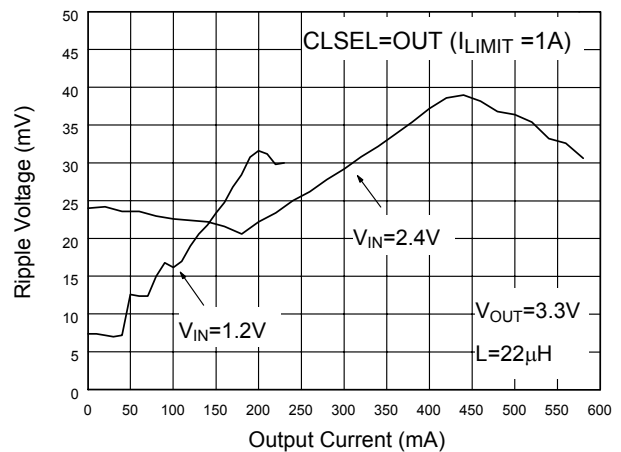

Fig. 46 Ripple Voltage (ref. to Fig.40)

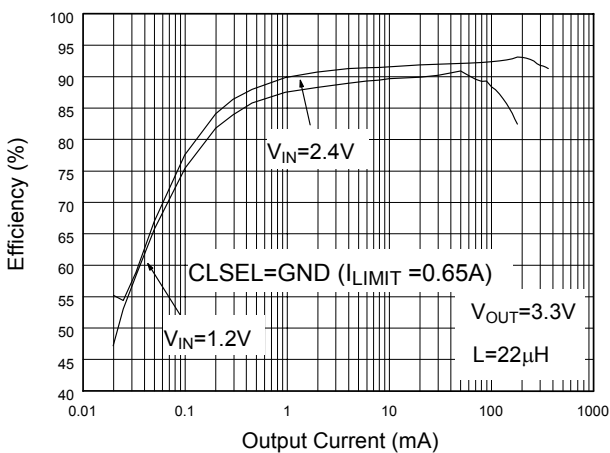

Fig. 47 Efficiency (ref. to Fig.40)

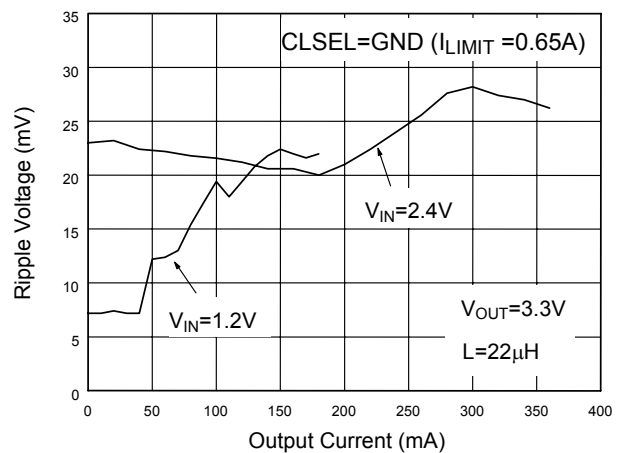
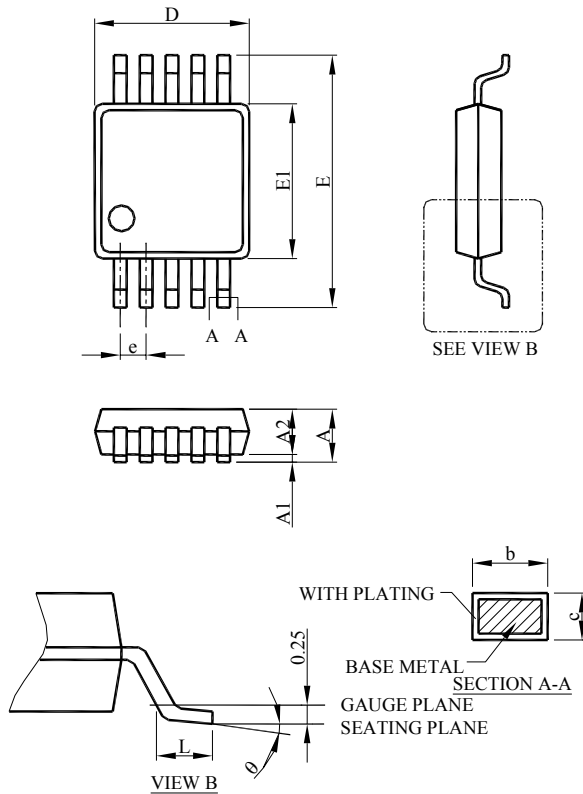

Fig. 48 Ripple Voltage (ref. to Fig.40)

PHYSICAL DIMENSION (unit: mm)
MSOP-10

SYMBOL	MSOP-10	
	MILLIMETERS	
	MIN.	MAX.
A		1.10
A1	0.05	0.15
A2	0.75	0.95
b	0.15	0.30
c	0.13	0.23
D	2.90	3.10
E	4.90 BSC	
E1	2.90	3.10
e	0.50 BSC	
L	0.40	0.70
θ	0°	6°

Note:

Information provided by AIC is believed to be accurate and reliable. However, we cannot assume responsibility for use of any circuitry other than circuitry entirely embodied in an AIC product; nor for any infringement of patents or other rights of third parties that may result from its use. We reserve the right to change the circuitry and specifications without notice.

Life Support Policy: AIC does not authorize any AIC product for use in life support devices and/or systems. Life support devices or systems are devices or systems which, (i) are intended for surgical implant into the body or (ii) support or sustain life, and whose failure to perform, when properly used in accordance with instructions for use provided in the labeling, can be reasonably expected to result in a significant injury to the user.

This datasheet has been download from:

www.datasheetcatalog.com

Datasheets for electronics components.