



AH5020C Monolithic Analog Current Switch

General Description

This versatile dual monolithic JFET analog switch economically fulfills a wide variety of multiplexing and analog switching applications.

These switches may be driven directly from standard 5V logic.

The monolithic construction guarantees tight resistance match and track.

Features

- Interfaces with standard TTL
- "ON" resistance match
- Low "ON" resistance
- Very low leakage
- Large analog signal range
- High switching speed
- Excellent isolation between channels

2Ω
150Ω
50 pA
±10V peak
150 ns
80 dB
at 1 kHz

Applications

- A/D and D/A converters
- Micropower converters
- Industrial controllers
- Position controllers
- Data acquisition
- Active filters
- Signal multiplexers/demultiplexers
- Multiple channel AGC
- Quad compressors/expanders
- Choppers/demodulators
- Programmable gain amplifiers
- High impedance voltage buffer
- Sample and hold

For voltage switching applications see LF13201, LF13202, LF13331, LF13332, and LF13333 Analog Switch Family, or the CMOS Analog Switch Family.

Connection and Schematic Diagrams (All switches shown are for logical "1")

Dual-In-Line Package

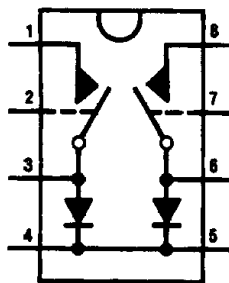

TL/H/5166-1

Top View

Order Number AH5020CJ
See NS Package Number J08A

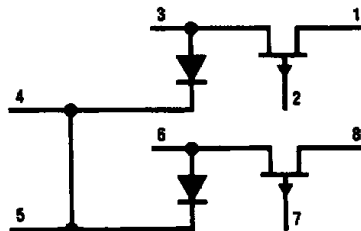

TL/H/5166-2

Note: All diode cathodes are internally connected to the substrate.

Absolute Maximum Ratings (Note 1)

If Military/Aerospace specified devices are required, please contact the National Semiconductor Sales Office/Distributors for availability and specifications.

Input Voltage	30V
Positive Analog Signal Voltage	30V
Negative Analog Signal Voltage	-15V
Diode Current	10 mA

Drain Current	30 mA
Power Dissipation	500 mW
Operating Temp. Range	-25°C to +85°C
Storage Temperature Range	-65°C to +150°C
Lead Temp. (Soldering, 10 seconds)	300°C

Electrical Characteristics (Notes 2 and 3)

Symbols	Parameter	Conditions	Typ	Max	Units
I_{GSX}	Input Current "OFF"	$V_{GD} = 4.5V, V_{SD} = 0.7V$	0.01	0.1	nA
		$V_{GD} = 11V, V_{SD} = 0.7V$	0.01	0.2	nA
		$T_A = 85^\circ C, V_{GD} = 11V, V_{SD} = 0.7V$		10	nA
$I_{D(OFF)}$	Leakage Current "OFF"	$V_{SD} = 0.7V, V_{GS} = 3.8V$ $T_A = 85^\circ C$	0.01	0.2 10	nA nA
$I_{G(ON)}$	Leakage Current "ON"	$V_{GD} = 0V, I_S = 1 mA$ $T_A = 85^\circ C$	0.08	1 200	nA nA
$I_{G(ON)}$	Leakage Current "ON"	$V_{GD} = 0V, I_S = 2 mA$ $T_A = 85^\circ C$	0.13	5 10	nA μA
$I_{G(ON)}$	Leakage Current "ON"	$V_{GD} = 0V, I_S = -2 mA$ $T_A = 85^\circ C$	0.1	10 20	nA μA
$r_{DS(ON)}$	Drain-Source Resistance	$V_{GS} = 0.5V, I_S = 2 mA$ $T_A = +85^\circ C$	90	150 240	Ω Ω
V_{DIODE}	Forward Diode Drop	$I_D = 0.5 mA$		0.8	V
$r_{DS(ON)}$	Match	$V_{GS} = 0, I_D = 1 mA$	2	20	Ω
T_{ON}	Turn "ON" Time	See ac Test Circuit	150	500	ns
T_{OFF}	Turn "OFF" Time	See ac Test Circuit	300	500	ns
CT	Cross Talk	See ac Test Circuit	120		dB

Note 1: Absolute Maximum Ratings indicate limits beyond which damage to the device may occur. DC and AC electrical specifications do not apply when operating the device beyond its specified operating conditions.

Note 2: Test conditions 25°C unless otherwise noted.

Note 3: "OFF" and "ON" notation refers to the conduction state of the FET switch.

Note 4: Thermal Resistance:

θ_{JA} (Junction to Ambient) N/A
 θ_{JC} (Junction to Case) N/A

Test Circuits

AC Test Circuit

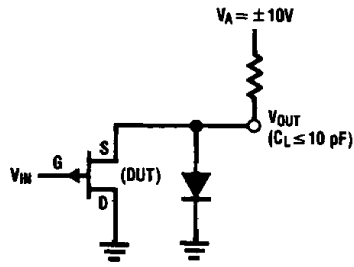

TL/H/5166-4

Cross Talk Test Circuit

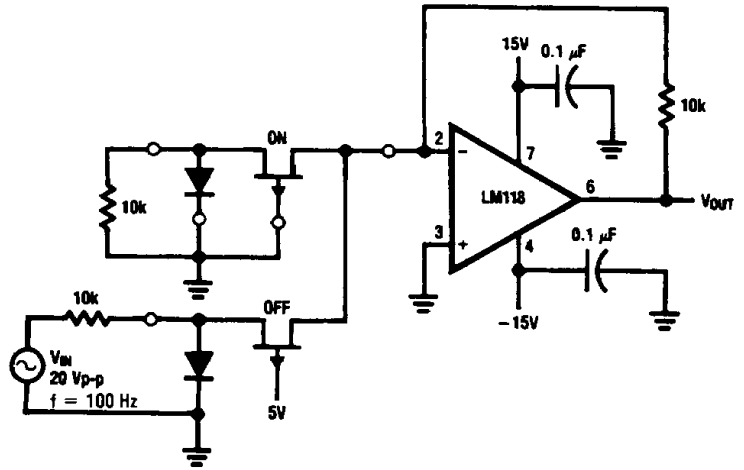

TL/H/5166-3

Switching Time Waveforms

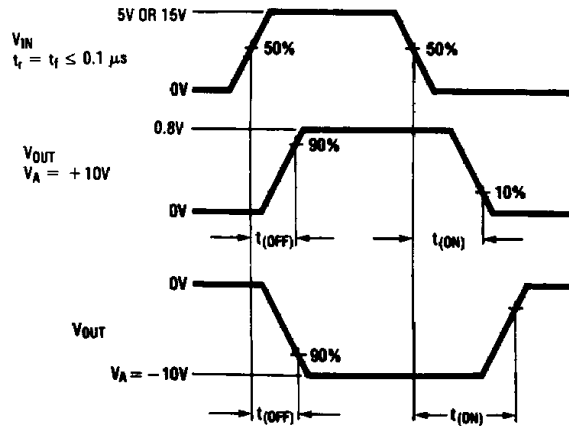

TL/H/5166-5

Typical Performance Characteristics

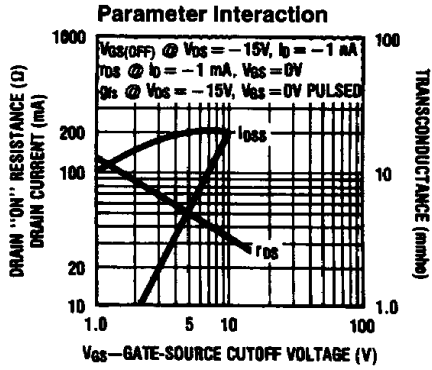

TL/H/5166-6

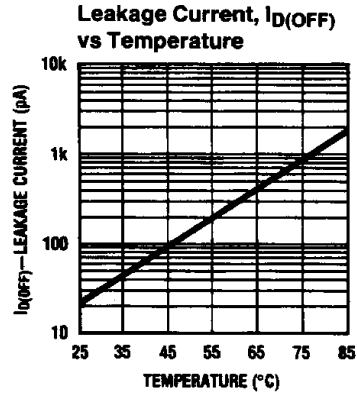

TL/H/5166-7

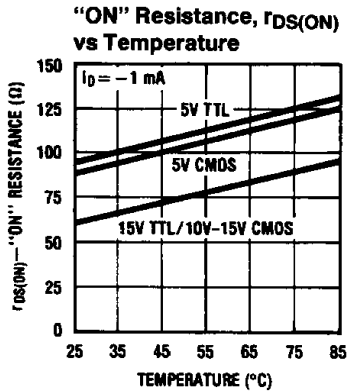

TL/H/5166-8

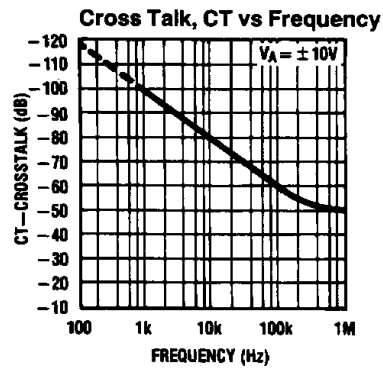

TL/H/5166-9

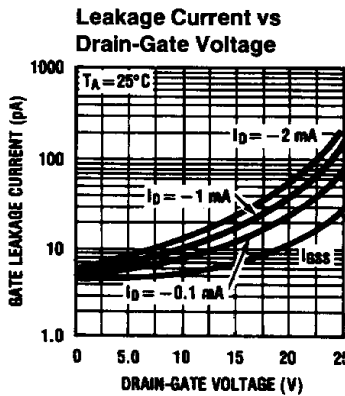

TL/H/5166-10

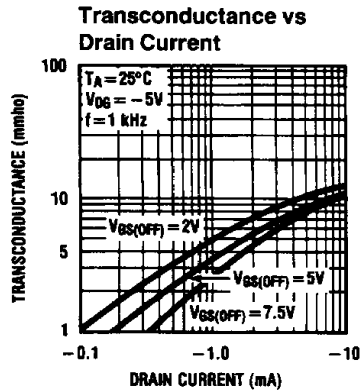

TL/H/5166-11

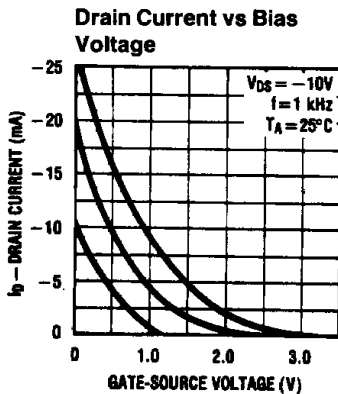

TL/H/5166-12

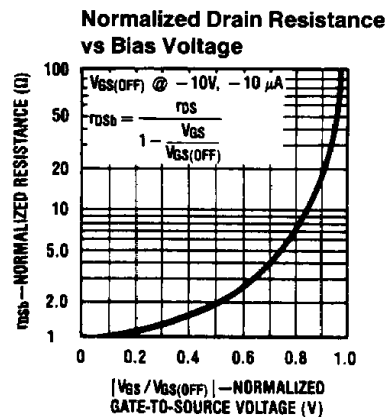

TL/H/5166-13

Applications Information

THEORY OF OPERATION

The AH5020 analog switches are primarily intended for operation in current mode switch applications; i.e., the drains of the FET switch are held at or near ground by operating into the summing junction of an operational amplifier. Limiting the drain voltage to under a few hundred millivolts eliminates the need for a special gate driver, allowing the switches to be driven directly by standard TTL.

If only one of the two switches in each package is used to apply an input signal to the input of an op amp, the other switch FET can be placed in the feedback path in order to compensate for the "ON" resistance of the switch FET as shown in *Figure 1*.

The closed-loop gain of *Figure 1* is:

$$A_{VCL} = - \frac{R2 + r_{DS(ON)Q2}}{R1 + r_{DS(ON)Q1}}$$

For $R1 = R2$, gain accuracy is determined by the $r_{DS(ON)}$ match between Q1 and Q2. Typical match between Q1 and Q2 is 2Ω resulting in a gain accuracy of 0.02% (for $R1 = R2 = 10\text{ k}\Omega$).

NOISE IMMUNITY

The switches with the source diodes grounded exhibit improved noise immunity for positive analog signals in the "OFF" state. With $V_{IN} = 15\text{V}$ and the $V_A = 10\text{V}$, the source of Q1 is clamped to about 0.7V by the diode ($V_{GS} = 14.3\text{V}$) ensuring that ac signals imposed on the 10V input will not gate the FET "ON".

SELECTION OF GAIN SETTING RESISTORS

Since the AH5020 analog switches are operated in current mode, it is generally advisable to make the signal current as large as possible. However, current through the FET switch tends to forward bias the source to gate junction and the signal shunting diode resulting in leakage through these junctions. As shown in *Figure 2*, $I_{G(ON)}$ represents a finite error in the current reaching the summing junction of the op amp.

Secondly, the $r_{DS(ON)}$ of the FET begins to "round" as I_S approaches I_{DSS} . A practical rule of thumb is to maintain I_S at less than $1/10$ of I_{DSS} .

Combining the criteria from the above discussion yields:

$$R1_{(MIN)} \geq \frac{V_A(MAX) A_D}{I_{G(ON)}} \quad (2a)$$

or:

$$\geq \frac{V_A(MAX)}{I_{DSS}/10} \quad (2b)$$

whichever is larger.

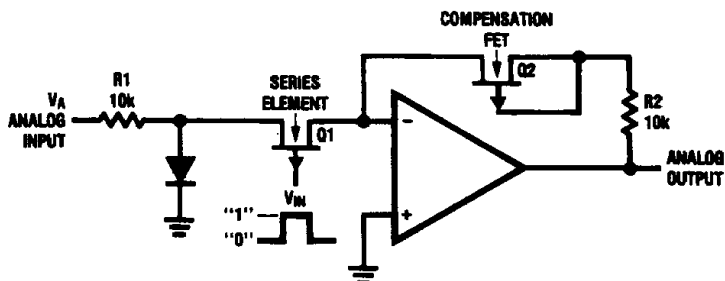

FIGURE 1. Use of Compensation FET

TL/H/5166-14

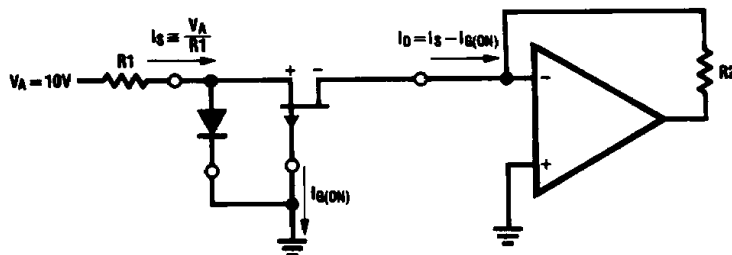

FIGURE 2. On Leakage Current, $I_{G(ON)}$

TL/H/5166-15

Applications Information (Continued)

Where $V_{A(MAX)}$ = Peak amplitude of the analog input signal
 A_D = Desired accuracy
 $I_{G(ON)}$ = Leakage at a given I_S
 I_{DSS} = Saturation current of the FET switch
 = 20 mA

In a typical application, V_A might = $\pm 10V$, $A_D = 0.1\%$, $0^\circ C \leq T_A \leq 85^\circ C$. The criterion of equation (2b) predicts:

$$R1_{(MIN)} \geq \frac{10V}{\frac{20 \text{ mA}}{10}} = 5 \text{ k}\Omega$$

For $R1 = 5k$, $I_S \cong 10V/5k$ or 2 mA. The electrical characteristics guarantee an $I_{G(ON)} \leq 1\mu A$ at $85^\circ C$ for the AH5020. Per the criterion of equation (2a):

$$R1_{(MIN)} \geq \frac{(10V)(10^{-3})}{1 \times 10^{-6}} \geq 10 \text{ k}\Omega$$

Since equation (2a) predicts a higher value, the 10k resistor should be used.

The "OFF" condition of the FET also affects gain accuracy. As shown in *Figure 3*, the leakage across Q2, $I_{D(OFF)}$ represents a finite error in the current arriving at the summing junction of the op amp.

Accordingly:

$$R1_{(MAX)} \leq \frac{V_{A(MIN)} A_D}{(N) I_{D(OFF)}}$$

Where $V_{A(MIN)}$ = Minimum value for the analog input signal

A_D = Desired accuracy
 N = Number of channels
 $I_{D(OFF)}$ = "OFF" leakage of a given FET switch

As an example, if $N=10$, $A_D=0.1\%$, and $I_{D(OFF)} \leq 10 \text{ nA}$ at $85^\circ C$ for the AH5020. $R1_{(MAX)}$ is:

$$R1_{(MAX)} \leq \frac{(1V)(10^{-3})}{(10)(10 \times 10^{-9})} = 10k$$

Selection of $R2$, of course, depends on the gain desired and for unity gain $R1 = R2$.

Lastly, the foregoing discussion has ignored resistor tolerances, input bias current and offset voltage of the op amp — all of which should be considered in setting the overall gain accuracy of the circuit.

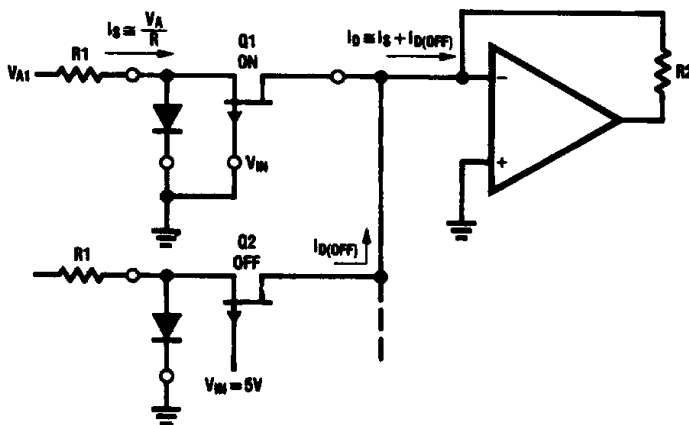

FIGURE 3. Off Leakage Current, $I_{D(OFF)}$

TL/H/5186-16

Applications Information (Continued)

TTL COMPATIBILITY

Standard TTL gates pull-up to about 3.5V (no load). In order to ensure turn-off of the AH5020, a pull-up resistor, R_{EXT} of at least 10 k Ω should be placed between the 5V V_{CC} and the gate output as shown in *Figure 4*.

DEFINITION OF TERMS

The terms referred to in the electrical characteristics tables are as defined in *Figure 5*.

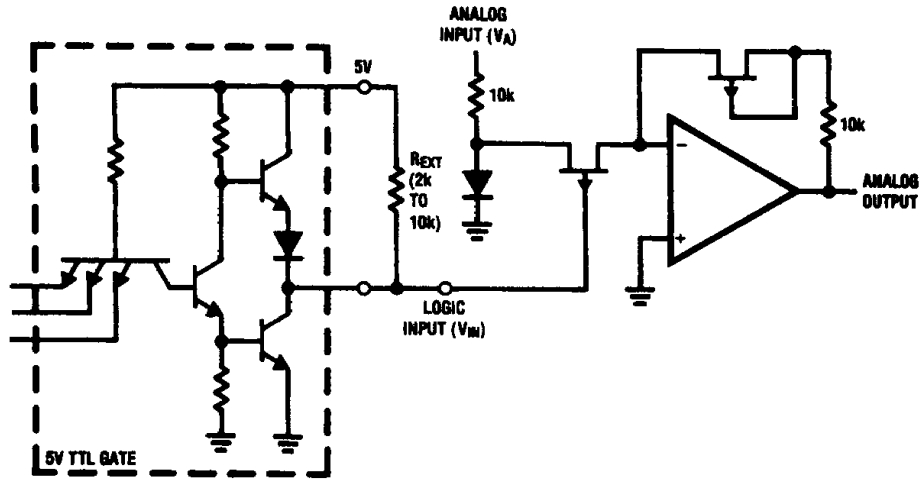

FIGURE 4. Interfacing with +5V TTL

TL/H/5166-17

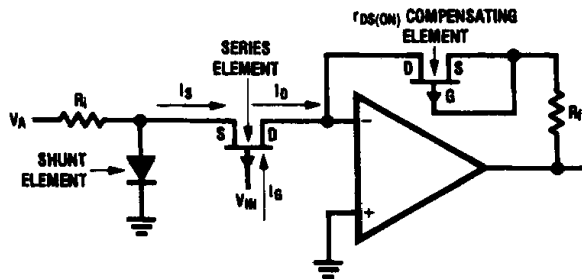
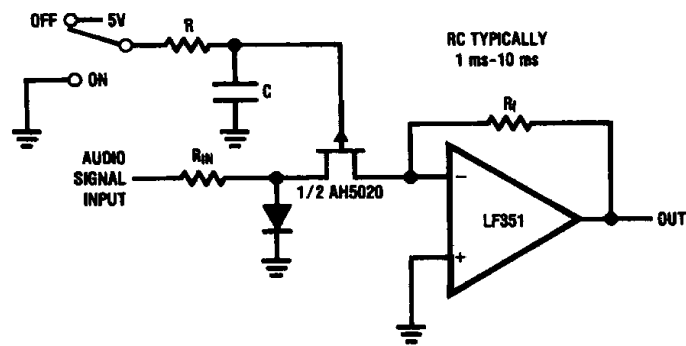

FIGURE 5. Definition of Terms

TL/H/5166-18

Typical Applications

Deglitched Switch for Noiseless Audio Switching



RC TYPICALLY
1 ms-10 ms

TL/H/5166-19

Gain Programmable Amplifier

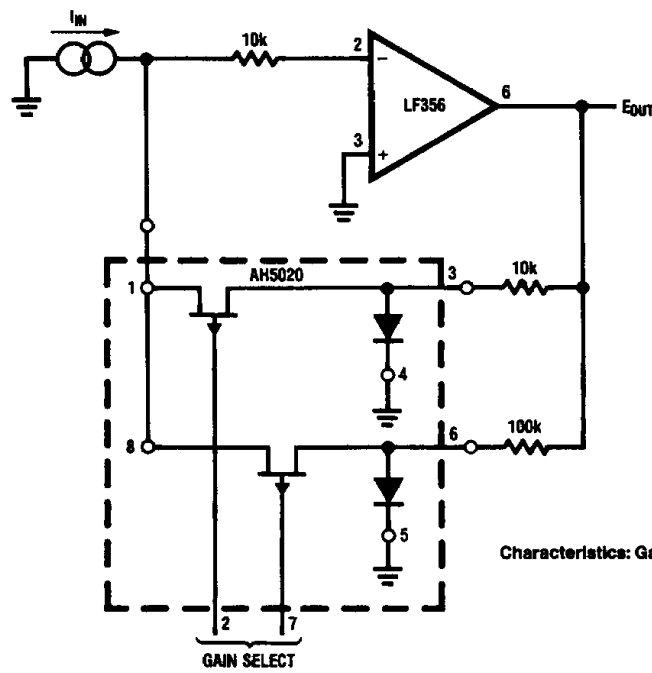

Characteristics: $\text{Gain} = \frac{-E_{OUT}}{I_{IN}} = R_{FS}$

TL/H/5166-20

2

This datasheet has been downloaded from:

www.DatasheetCatalog.com

Datasheets for electronic components.